

ZDD Technology for Concentrate Management in Groundwater Desalination

Thomas A. Davis, Director
Center for Inland Desalination Systems
Professor, Civil Engineering UTEP

Multi-State Salinity Coalition
Las Vegas, NV
February 18, 2010

The Real Cost of Desalination

- Removal from the source – whose is it?
- Capital Equipment
- Energy to separate salt and water
 - Thermal energy for evaporative processes
 - Electrical for RO and ED
- Greenhouse gases from energy production
- Disposition of the residual salt

Western half of USA is very dry.

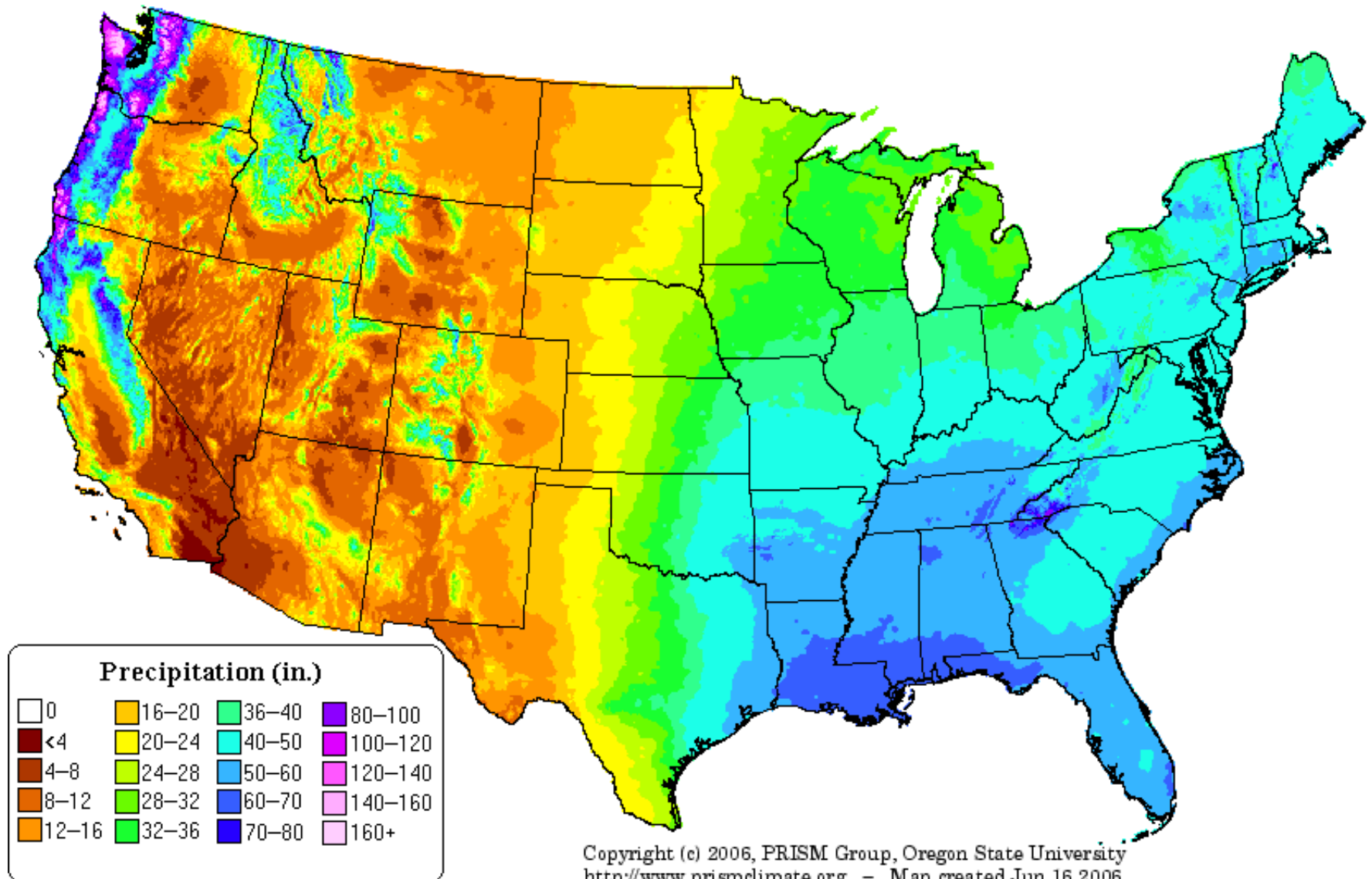

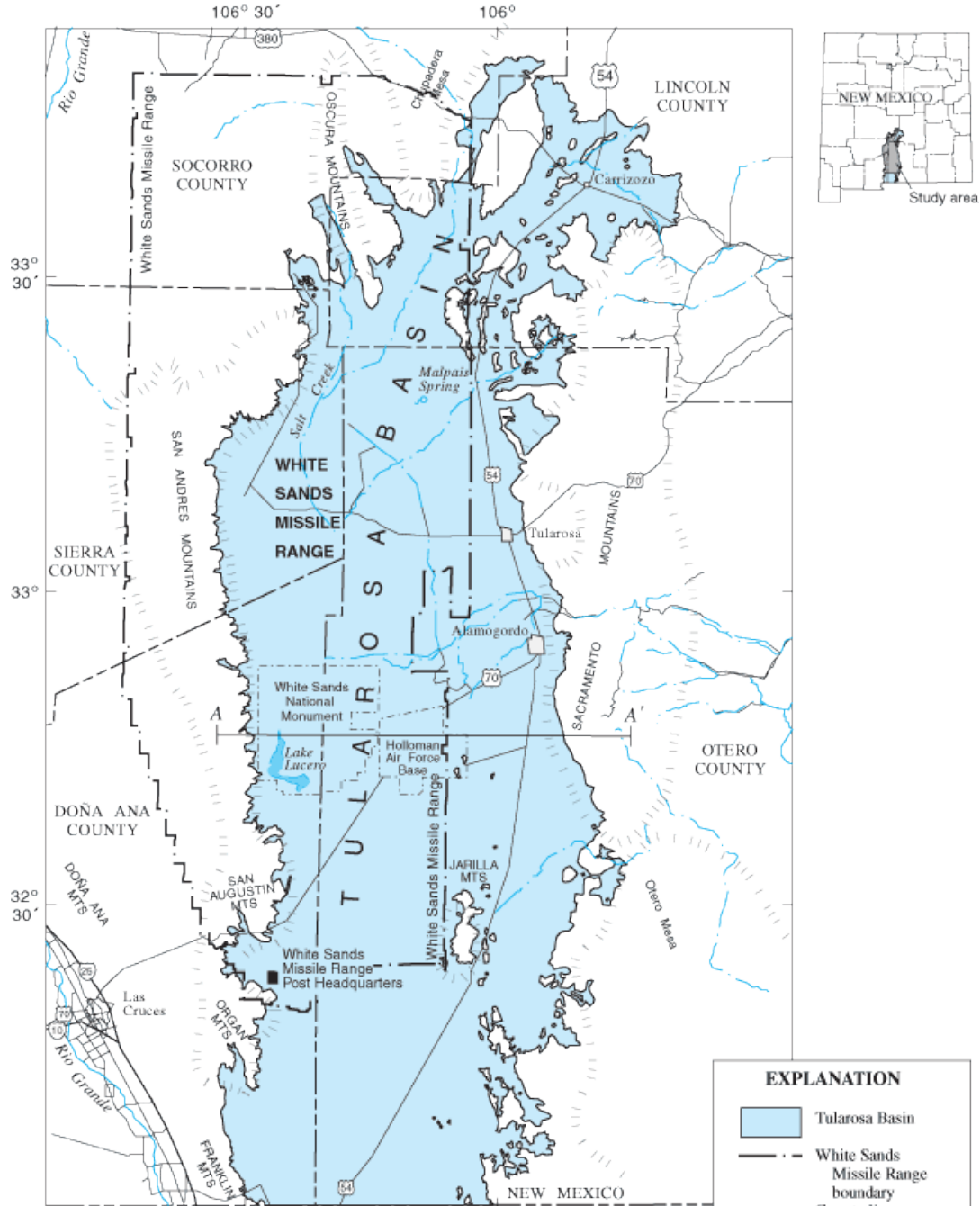

U.S. Geological Survey digital data, 1:100,000
 UTM, Zone 13, NAD83, GRS80

TEXAS

0 10 20 KILOMETERS

0 10 20 MILES

EXPLANATION

- Tularosa Basin
- White Sands Missile Range boundary
- County lines

A A'
 Line of section (fig. 2)

Incentives for New Mexico Study

- Groundwater in Tularosa Basin.
 - 10^8 acre-feed recoverable
 - nearly saturated with CaSO_4
- CaSO_4 scale formation limits desalination yield.
- Use of scale inhibitors improves yield, but concentrate disposal is still a problem.
- Existing methods for dealing with CaSO_4 scale don't eliminate concentrate disposal problems.
- Funding available for improving water yield.





Tularosa, NM, groundwater is nearly saturated with CaSO_4

Ion	mMol/L
Bicarbonate	4.43
Chloride	4.79
Sulfate	14.27
Calcium	10.48
Magnesium	6.7
Sodium	4.96

Conventional Electrodialysis (ED) is effective for removing and concentrating soluble salts.

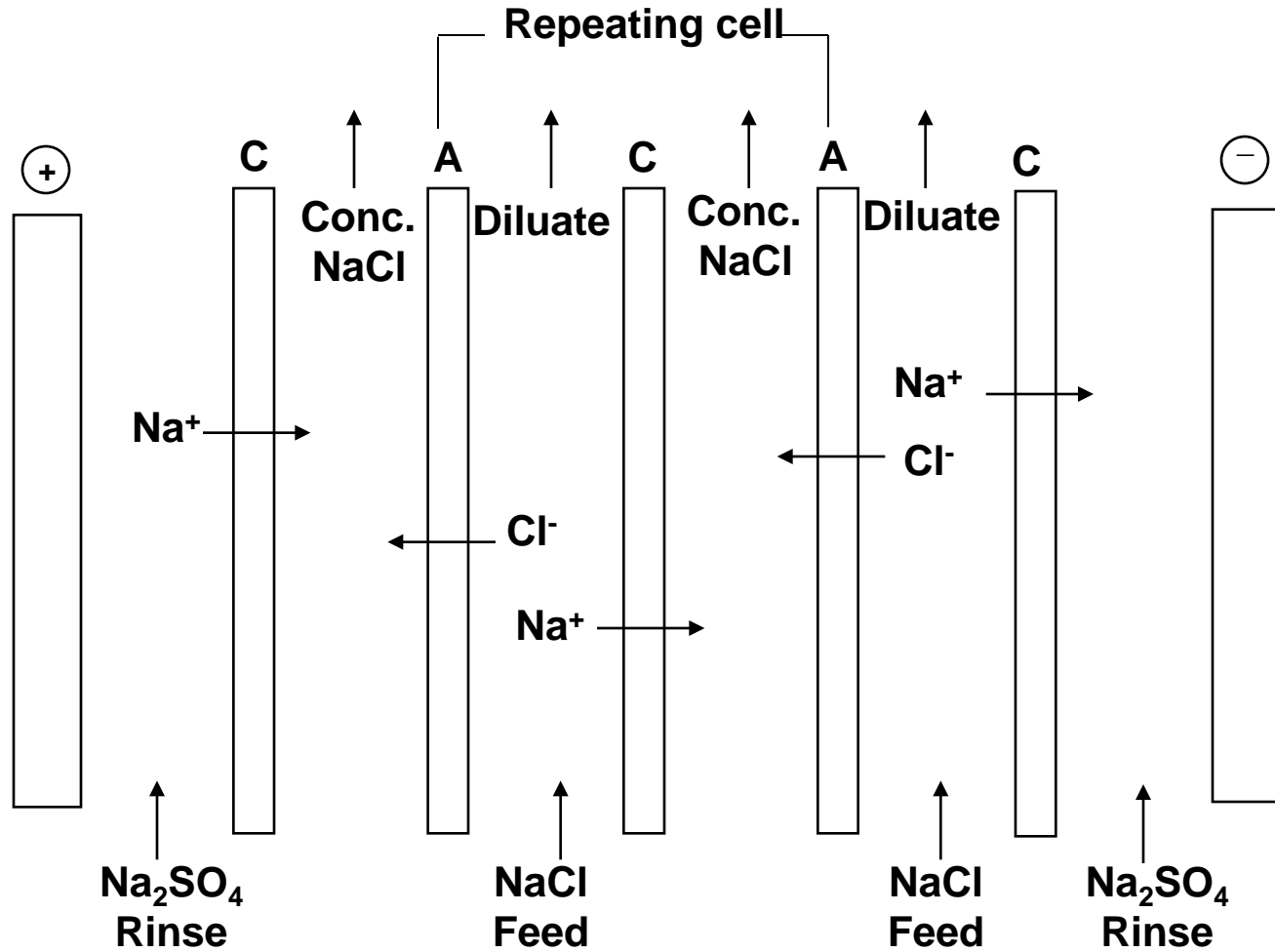

ED Metathesis uses 4-membrane cell. Ions change partners and form highly soluble salts.

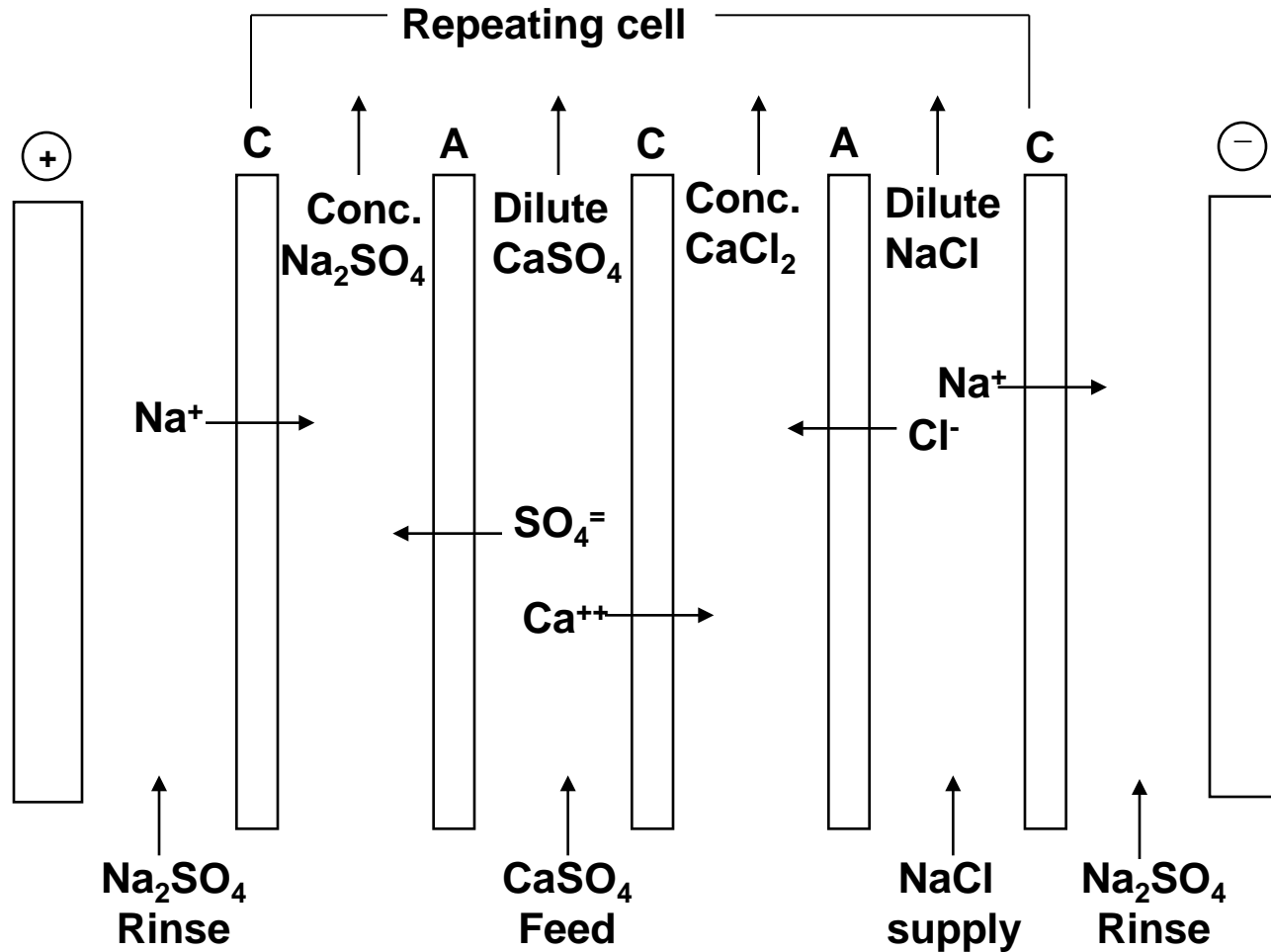

Highly soluble salts produced by EDM

Solubility of Salts in water

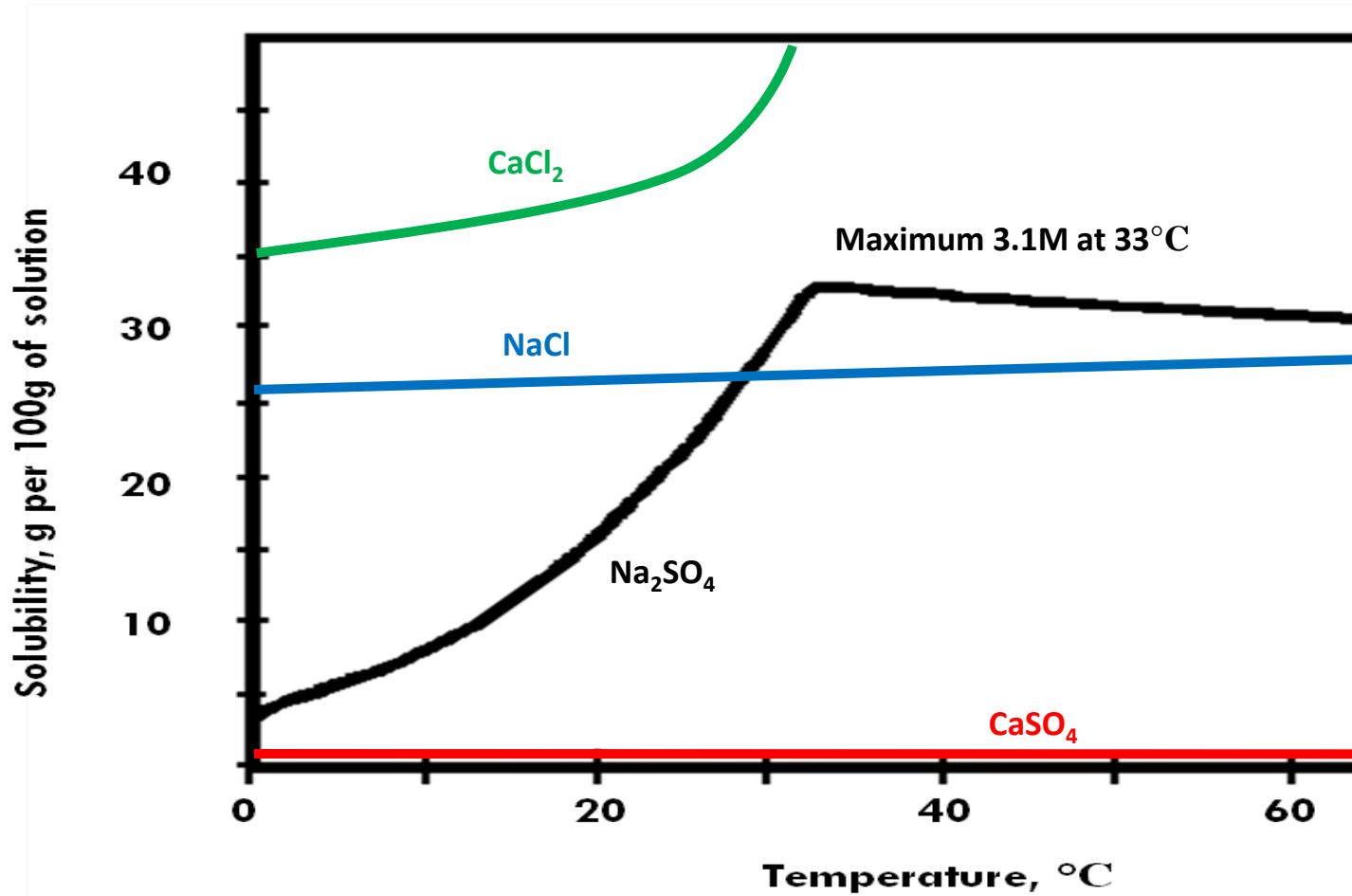

Transport of brackish water ions in EDM

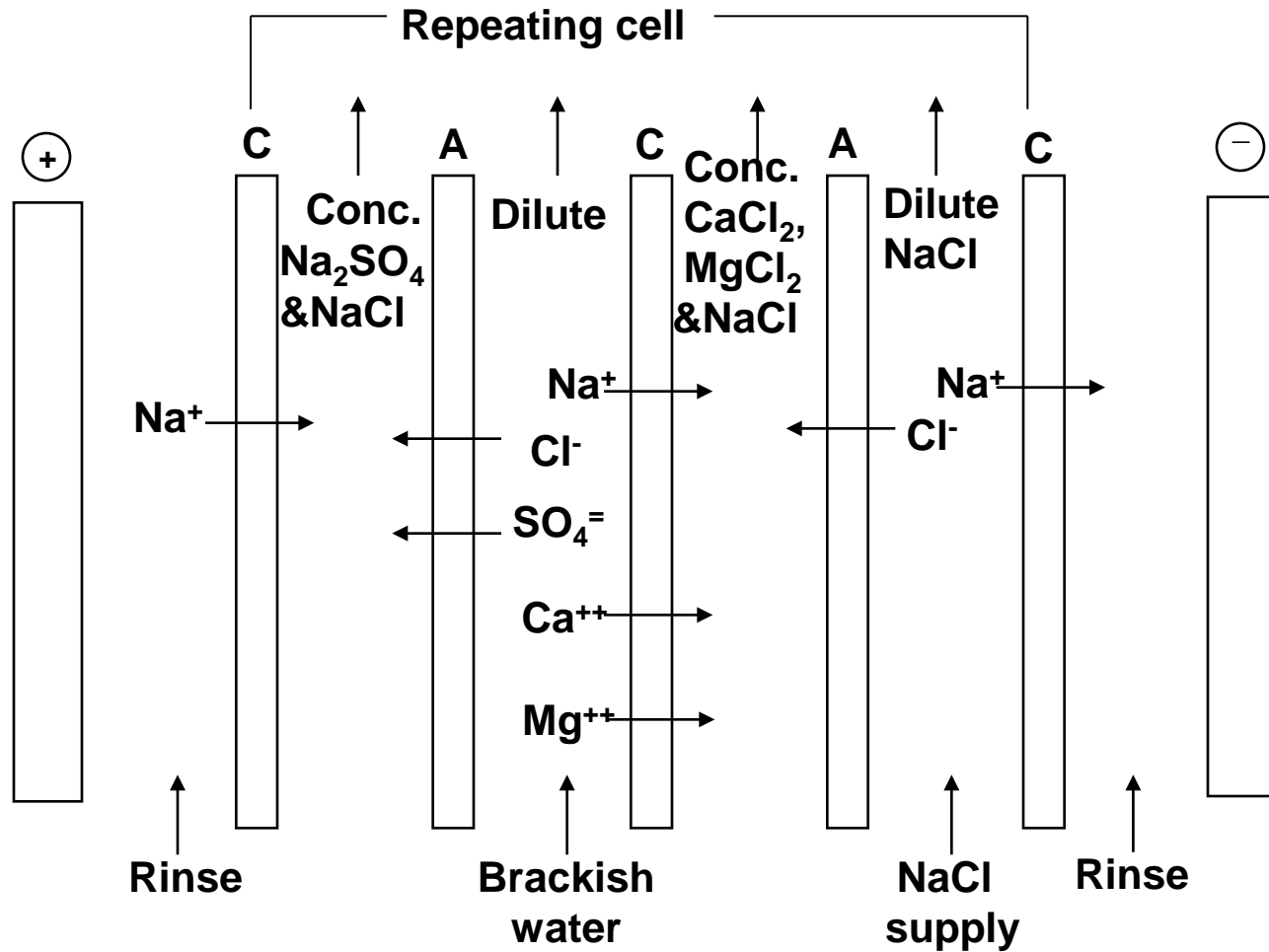

Mixing concentrate streams produces solid gypsum, small brine stream, 99% water yield.

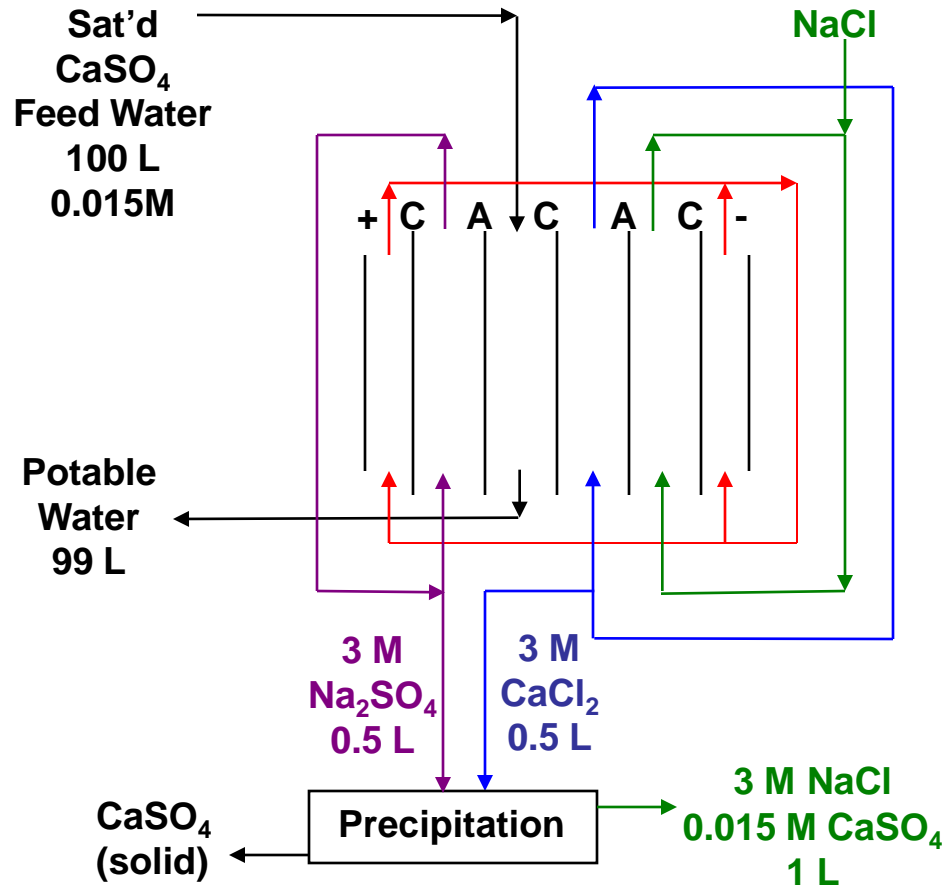

CaSO_4 crystals formed when concentrate streams were mixed in graduated cylinder.

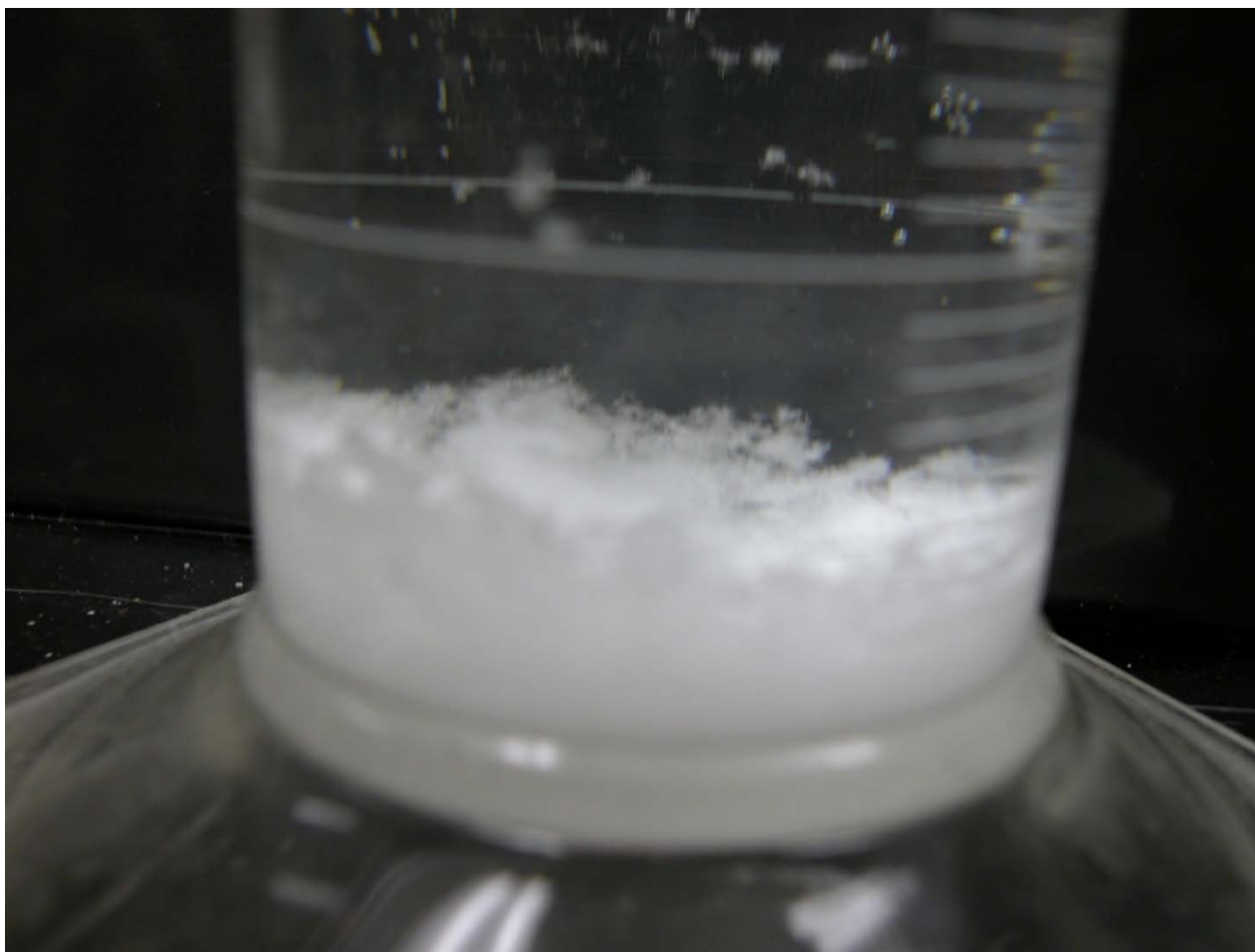

Hybrid process is more efficient.

- Ion flux in EDM is proportional to concentration of the most dilute process stream.
- Membrane area in EDM can be minimized by keeping feed as concentrated as possible.
- Use RO or NF to concentrate EDM diluate.
- Recover potable water from RO or NF.

Mixing concentrate streams produces solid gypsum and Mg-rich brine

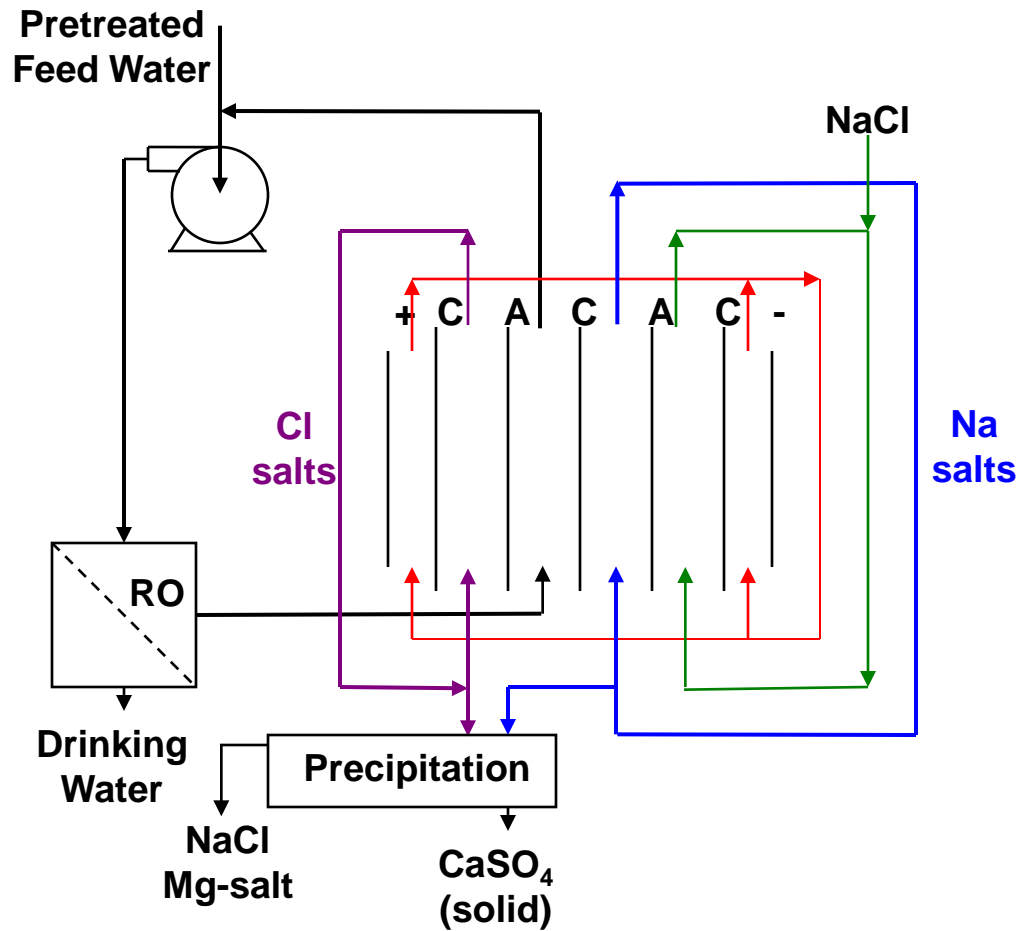

Common Feed Tank for Pilot Studies

Silica removal improves water recovery.

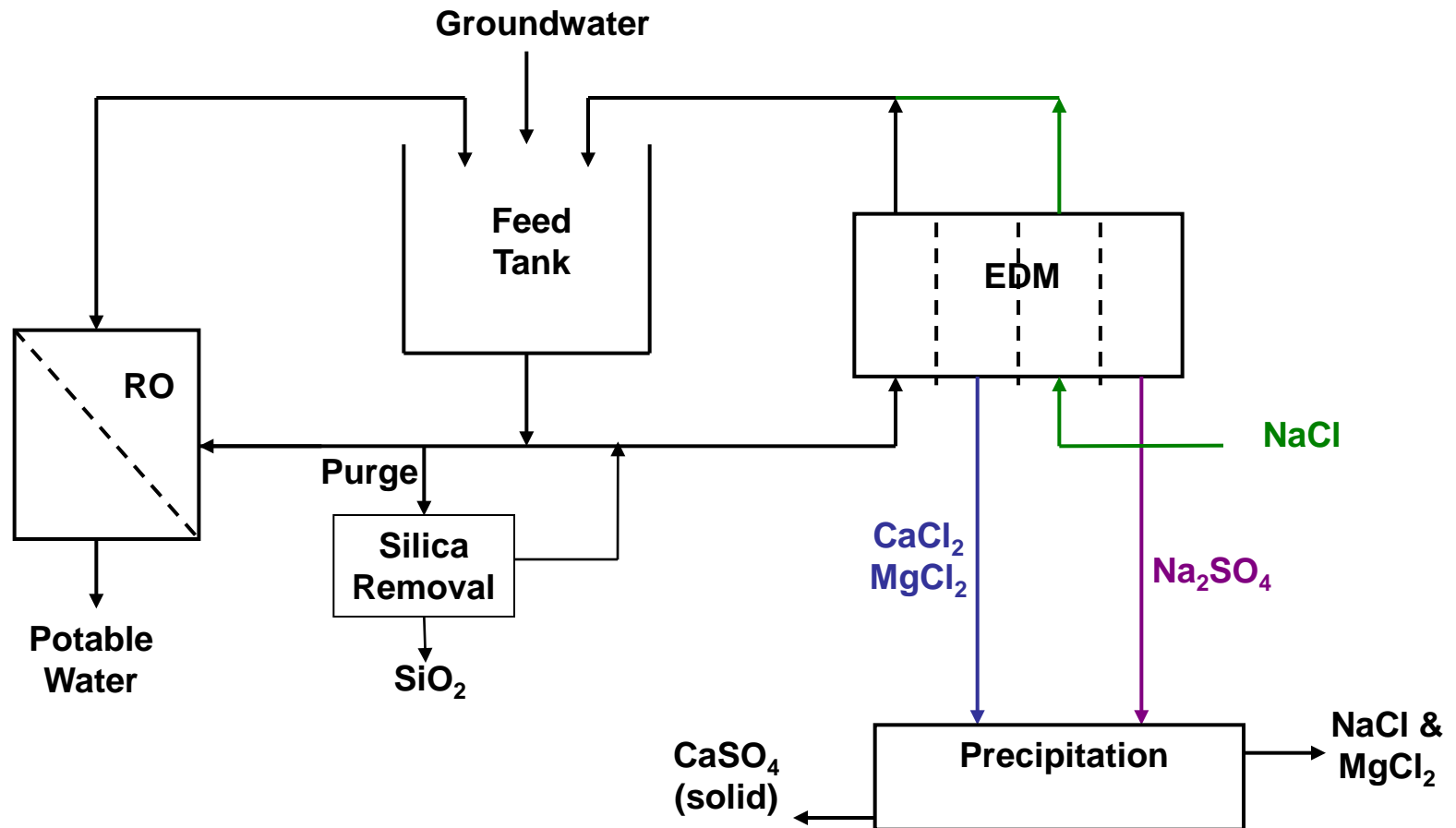

Magnesium salt remains after NaCl is recovered in ED2.

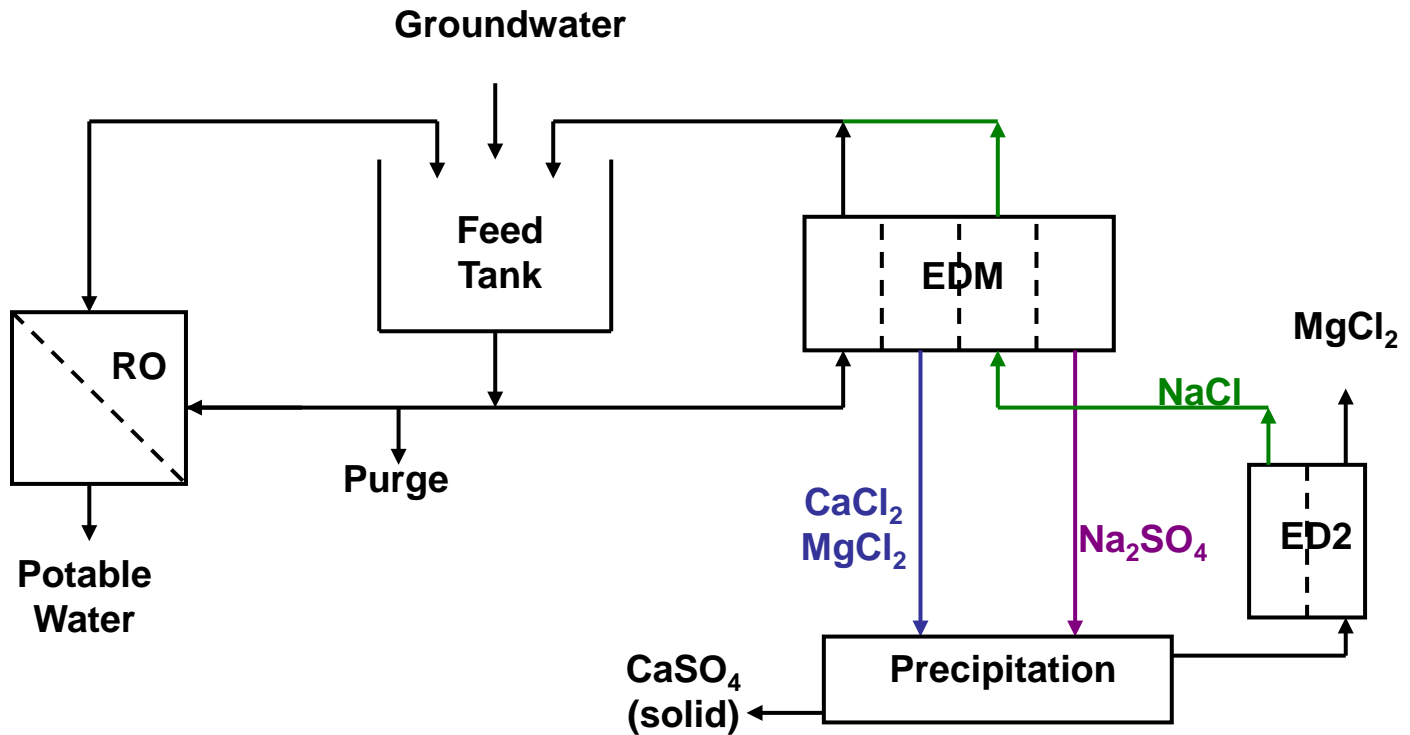

CaSO₄ and MgCl₂ are recovered as solids.

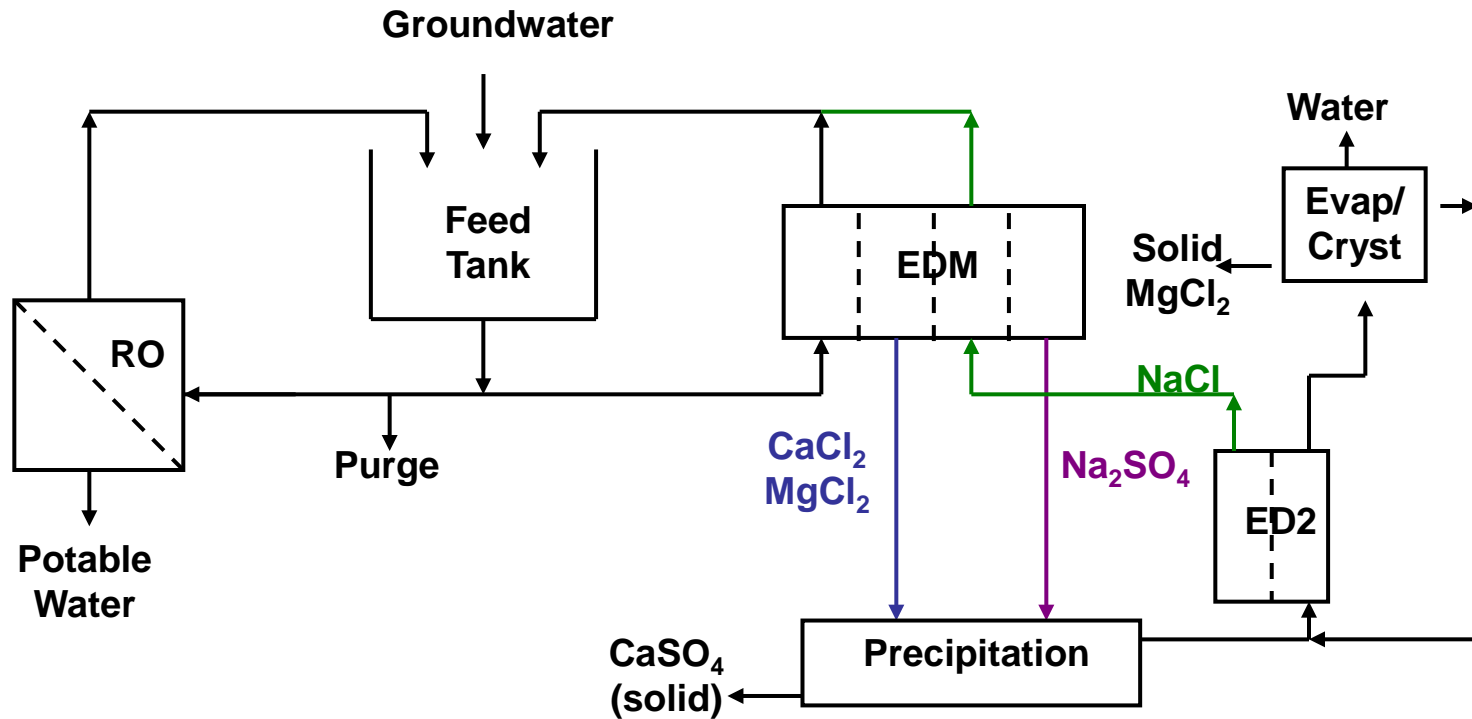

Excess Na_2SO_4 is removed by crystallization.

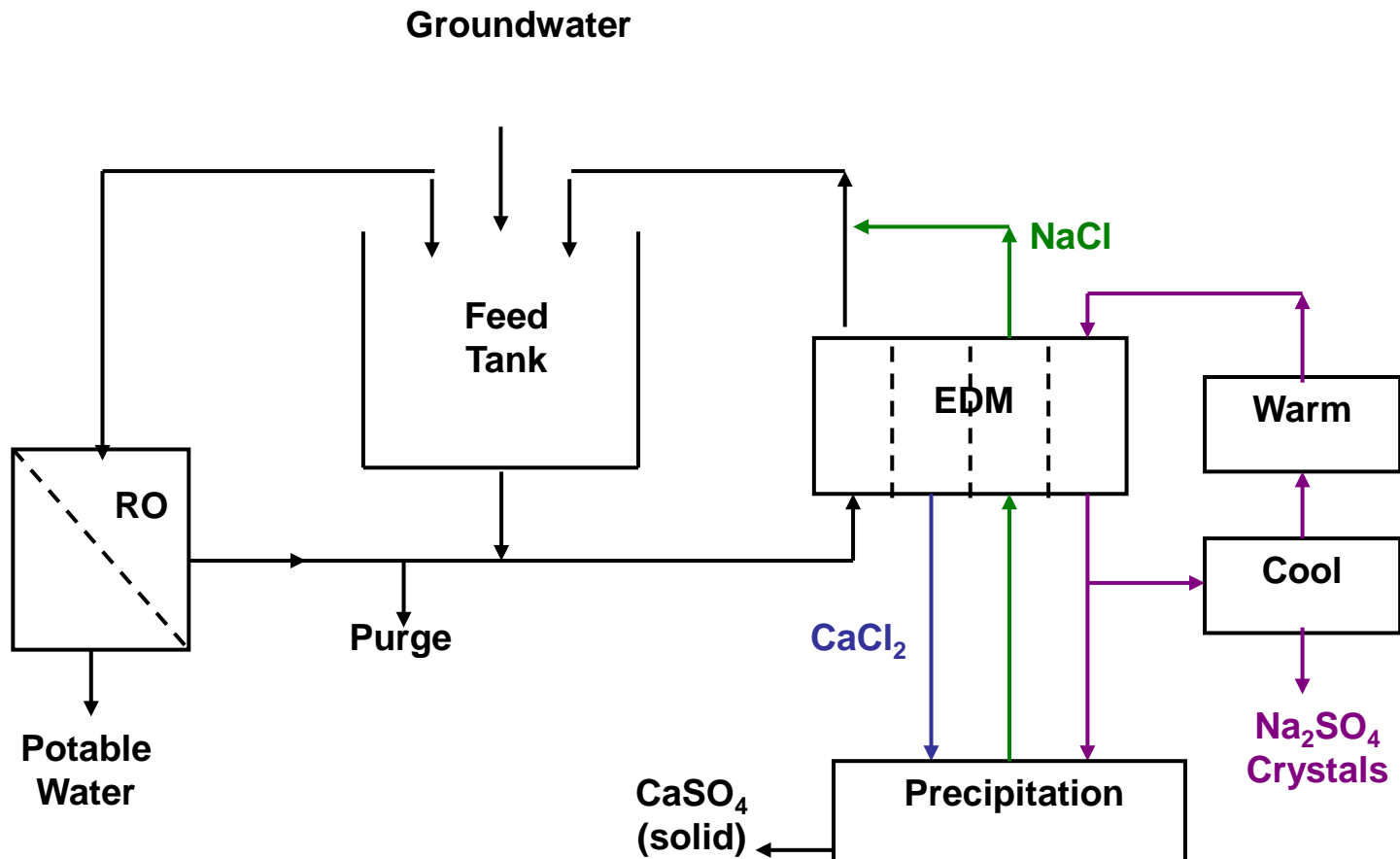

Crystal from Na_2SO_4 solution



Solubility of Na₂SO₄ in water

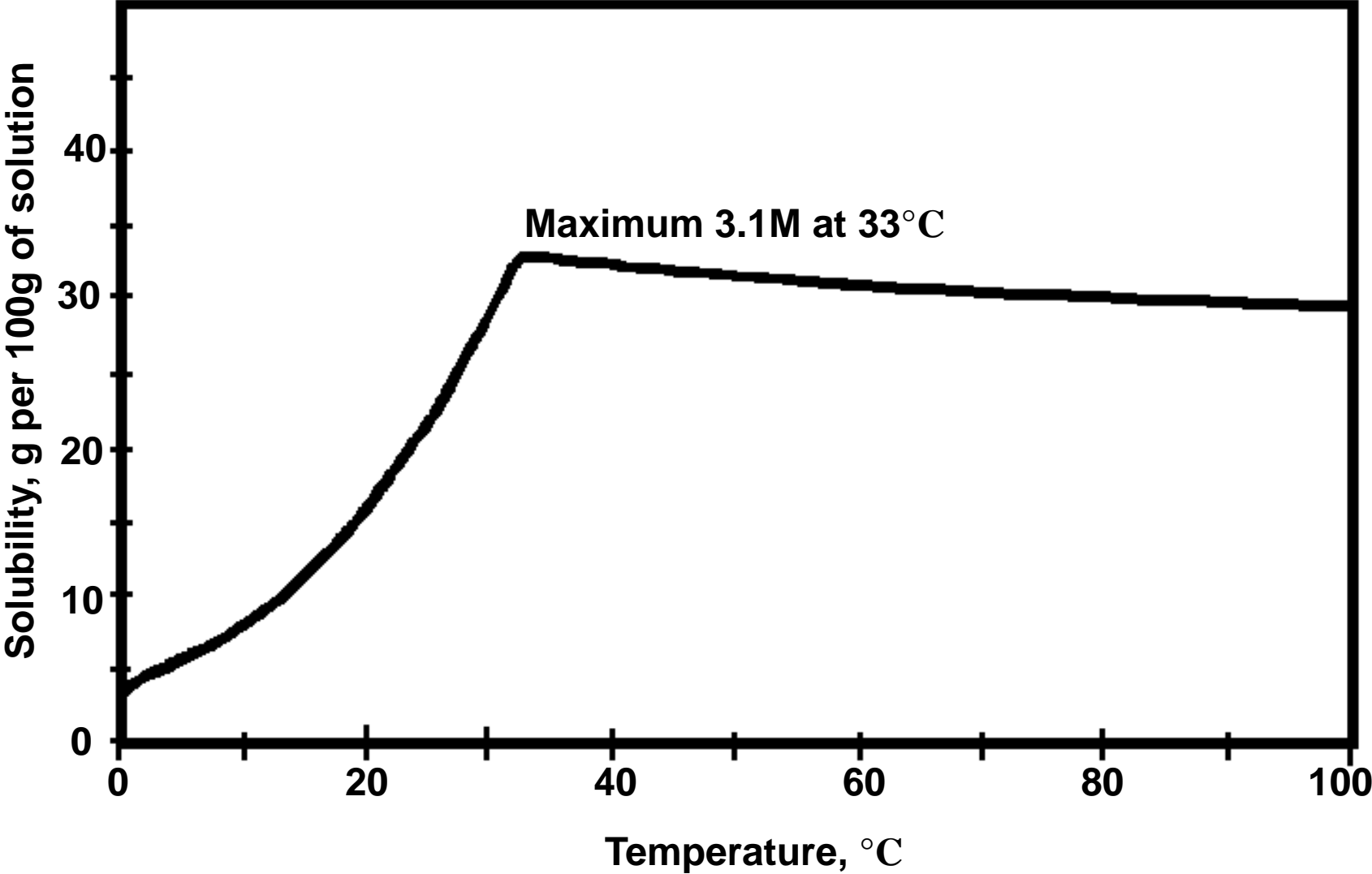

Pilot Studies of EDM process

- Panoche Water District in Calif.
 - Selenium removal
- El Paso – RO concentrate volume reduction
- Alamogordo groundwater
 - CaSO_4 is dominant salt
 - 97% yield of potable water



Summary

- EDM is the heart of the ZDD process
 - Recover separate concentrated Ca^{++} and SO_4^- streams
 - Mix concentrated streams to precipitate CaSO_4
 - Improve yield of fresh water
 - Approach zero liquid discharge
- Feed to EDM can come from
 - Reverse osmosis
 - Nanofiltration
 - Directly from water supply
- Peripheral processes for use as required
 - Recycle NaCl after purification
 - Recover Na_2SO_4 crystals
 - Recover Mg salts in solid form
 - Silica removal

Electrodialysis at Sanuki Salt Manufacturing Plant

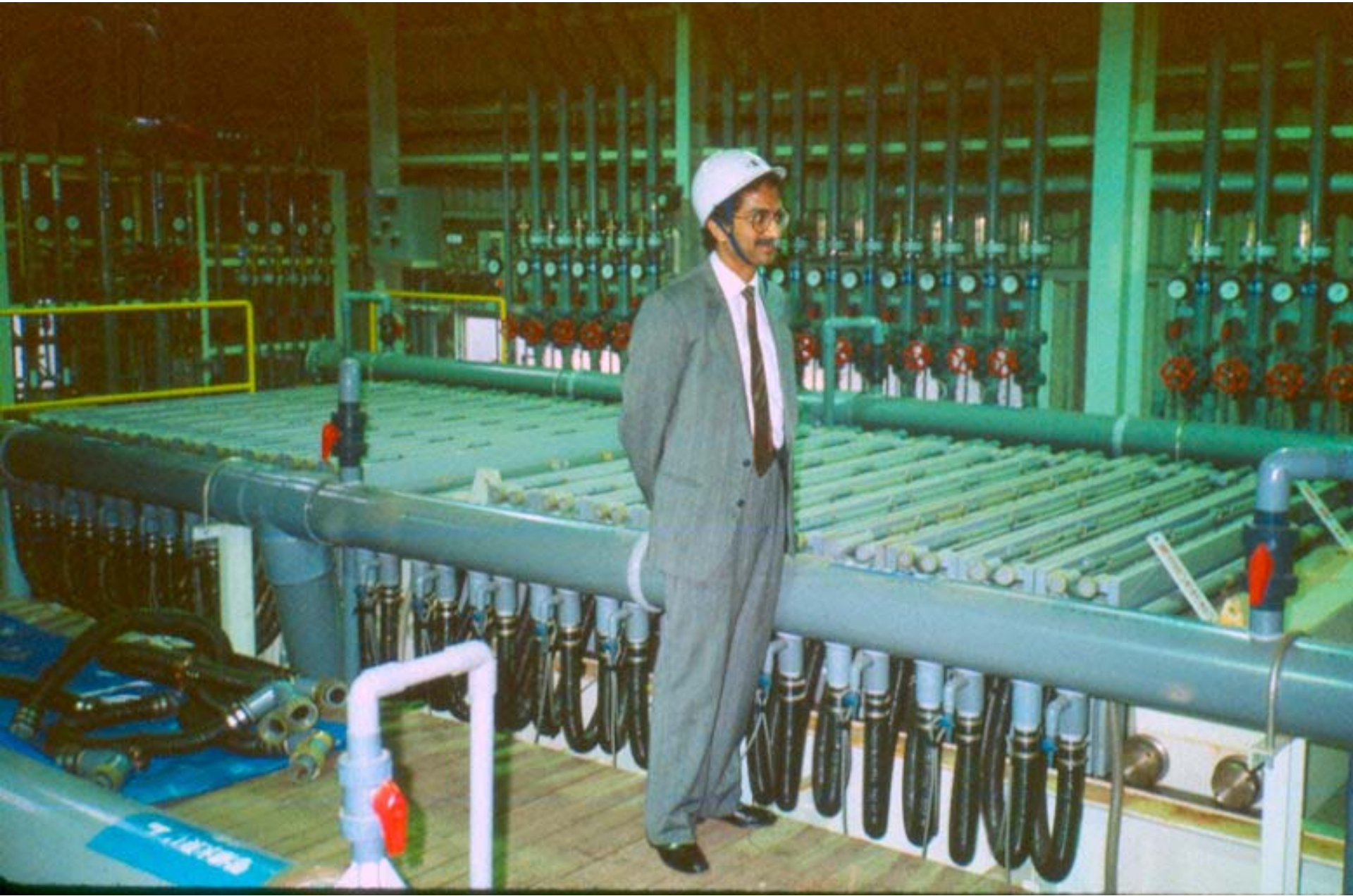

Acknowledgement

US Department of the Interior, Bureau of Reclamation
Sandia National Laboratories
Veolia

