

# CARBON AND ENERGY FOOTPRINT ANALYSES: DYNAMIC TOOLS FOR PROCESS OPTIMIZATION AND ENVIRONMENTAL IMPACT REDUCTION IN WATER AND WASTEWATER TREATMENT

**Diego Rosso**

**University of California, Irvine**  
Department of Civil & Environmental Engineering



**MSSC 2010**

***Annual Salinity Summit***

**Las Vegas, NV – February 18-19, 2010**

February 19<sup>th</sup>, 2010



# I. BACKGROUND



Q: Is WWT good for the environment?

A: YES!!

ENVIRONMENTAL  
IMPACT  
(ARBITRARY  
UNITS)

NO  
SA  
OR  
N  
D  
ON

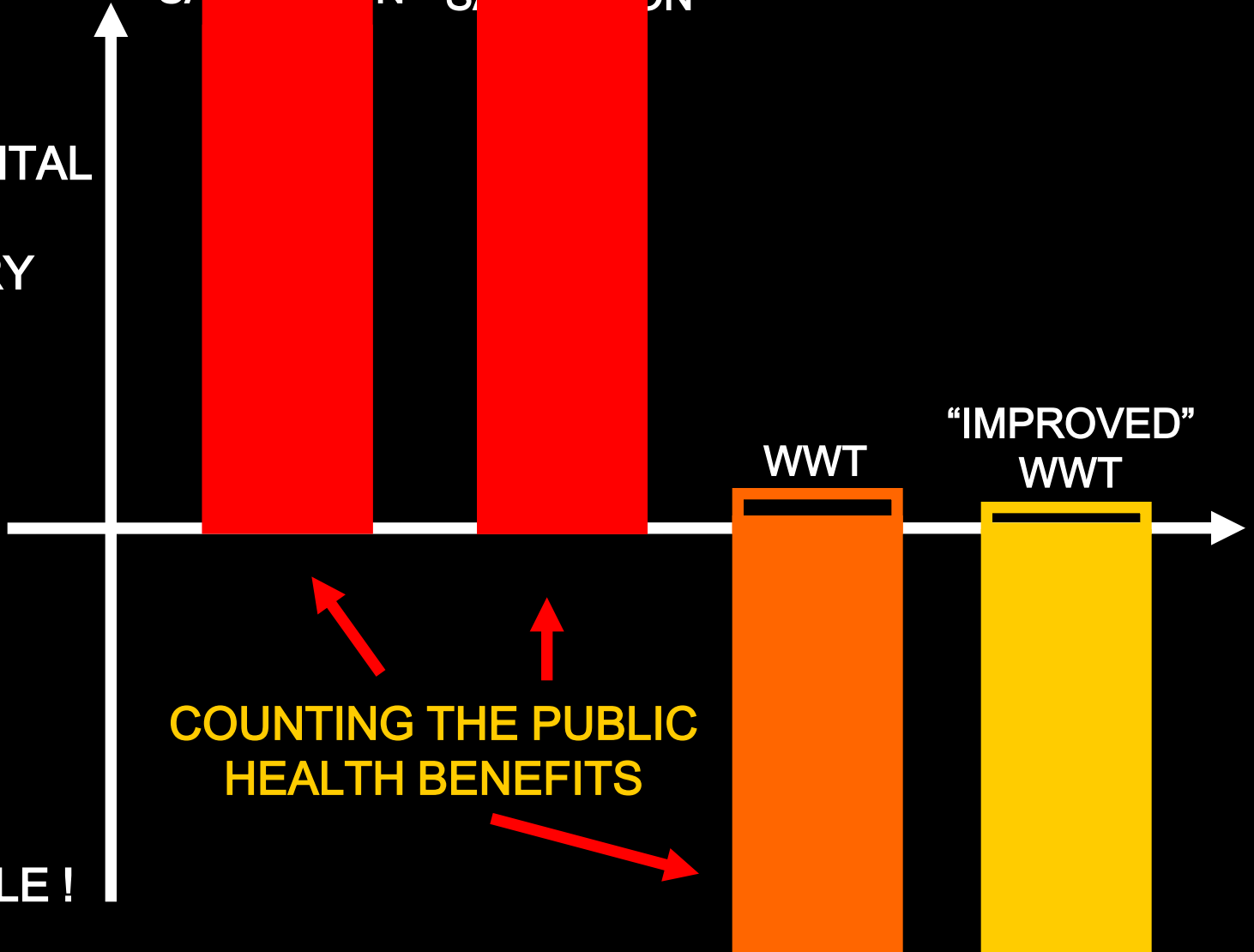

COUNTING THE PUBLIC  
HEALTH BENEFITS

NOT TO SCALE!

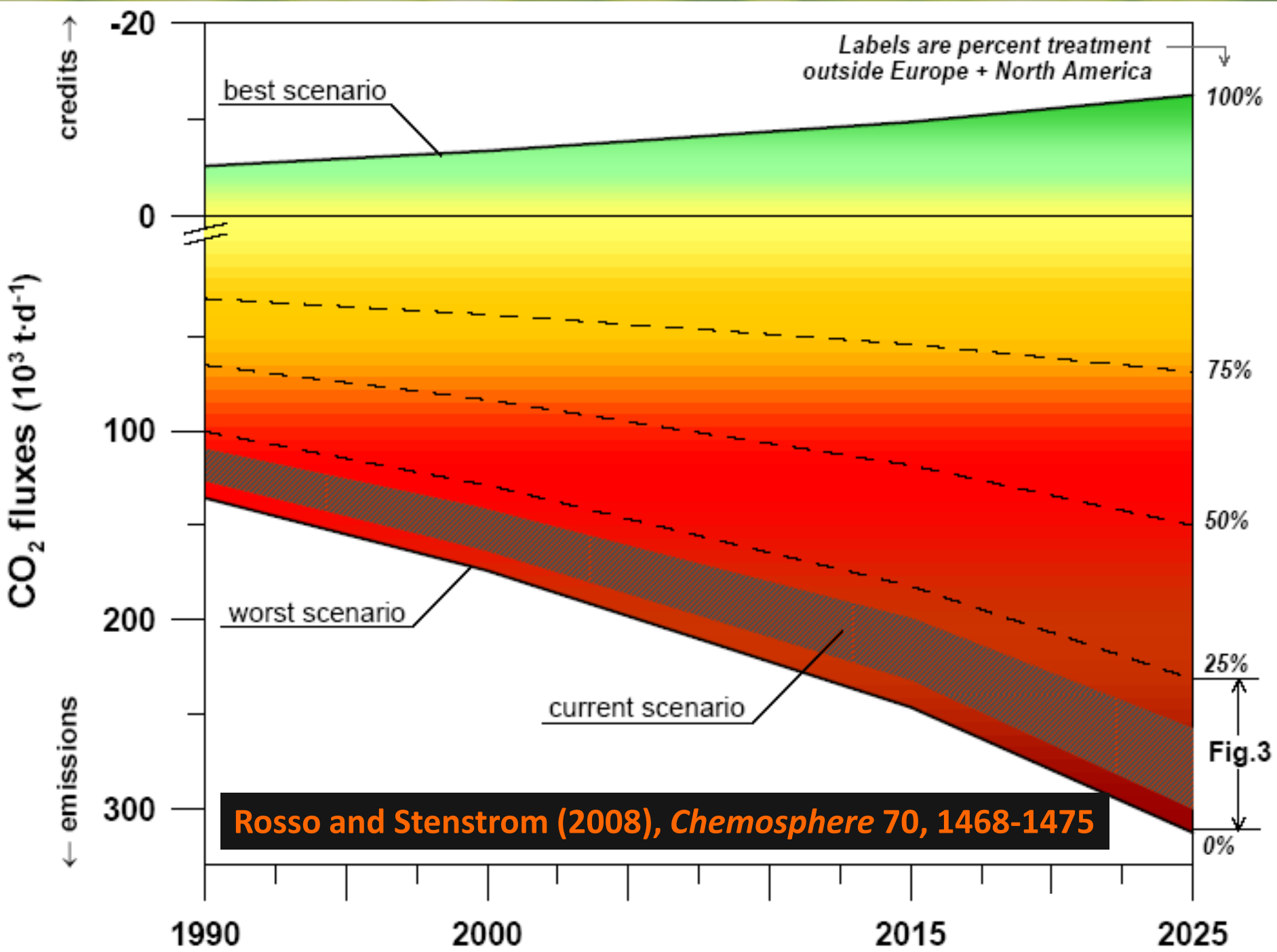

# Past, present, future

- Climate change and regulation
- In CA, AB32 requires utilities to compile a GHGeq inventory
- Overall GHGeq minimization is the current paradigm
- Emission factors widely used
- Uneven availability of data
- Not all emissions are fully understood yet

# WWT IN PERSPECTIVE

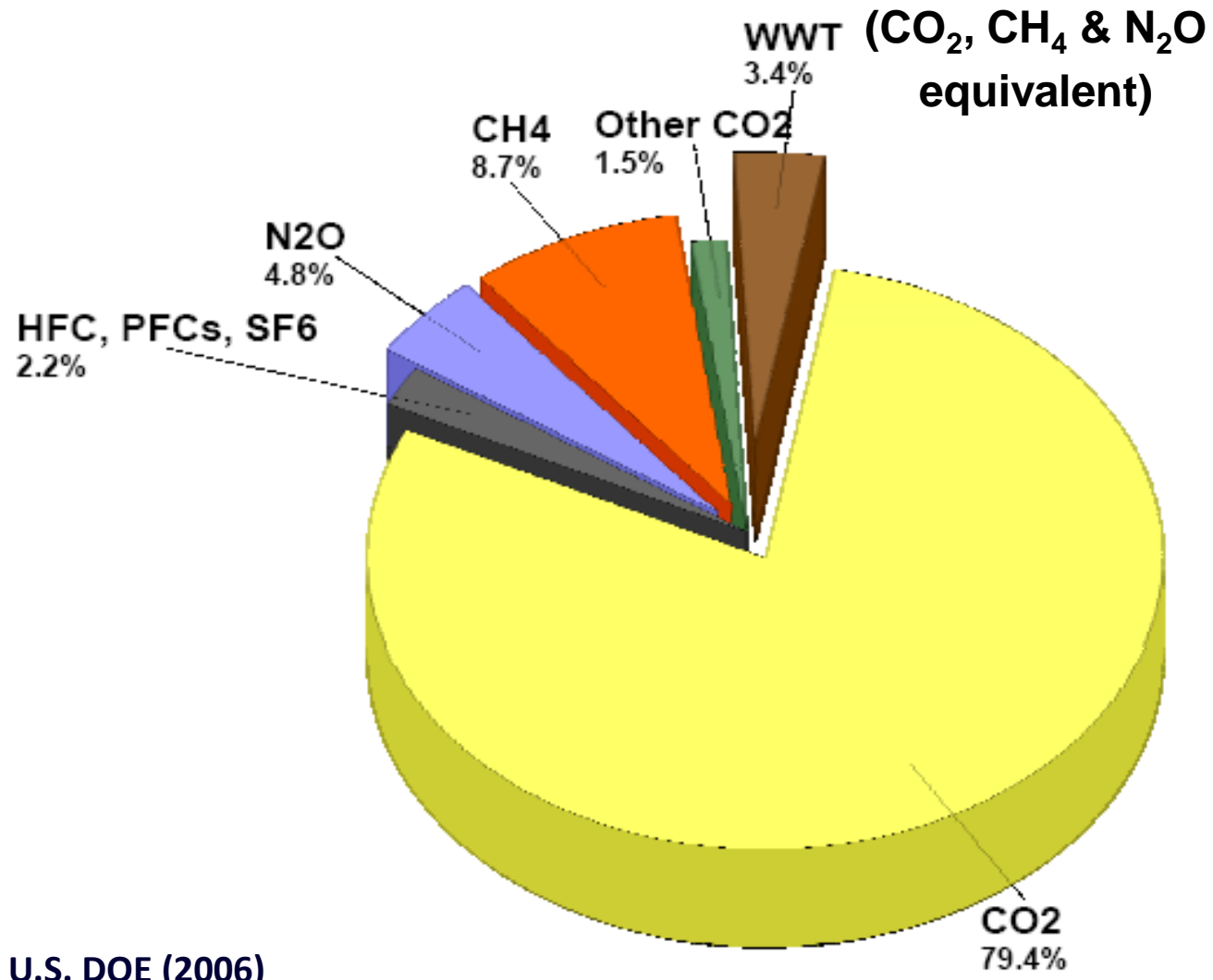

U.S. DOE (2006)

# Overall? Boundaries and Scopes

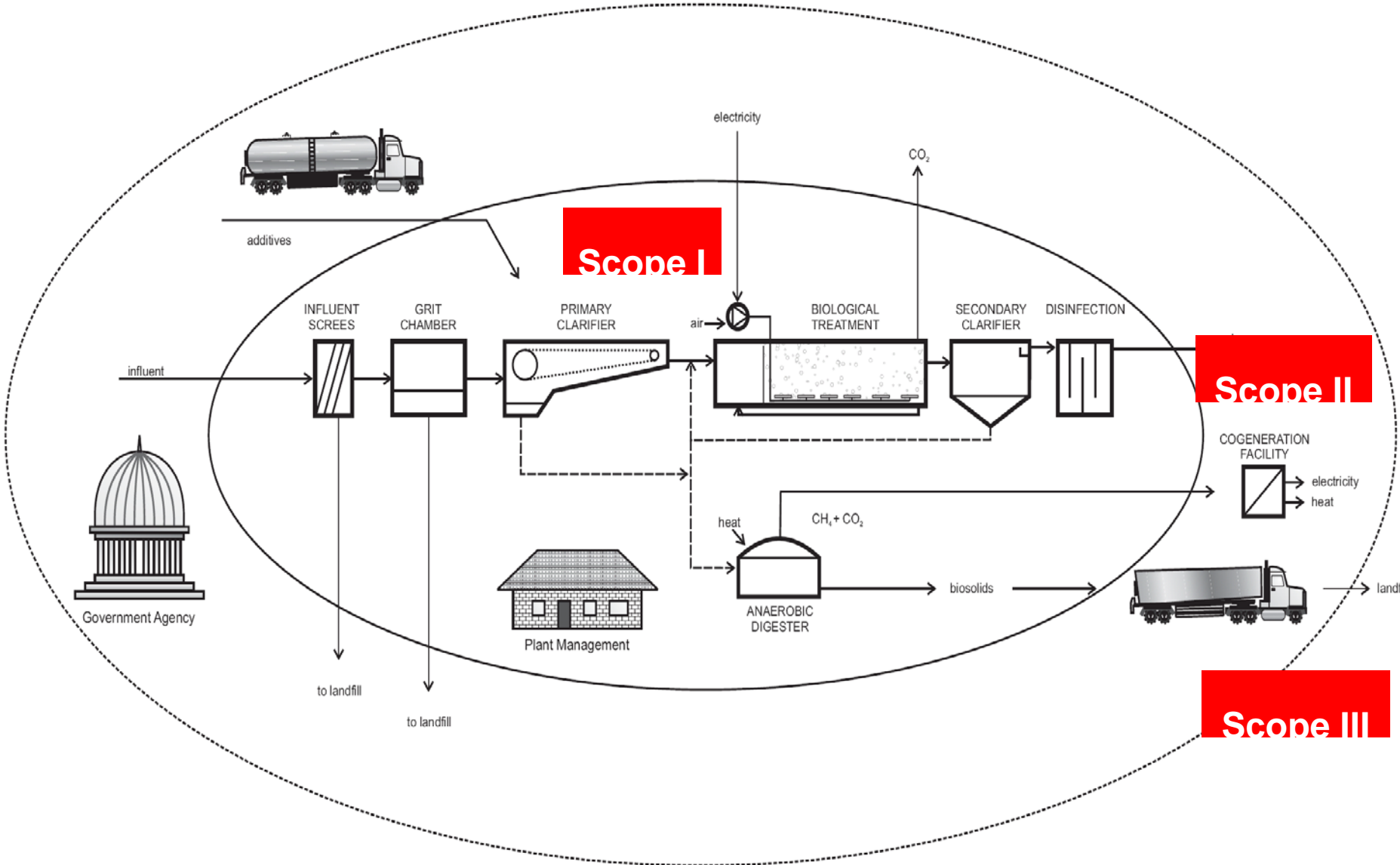

# LCA or CFP?

- CFP is a dynamic tool for modeling direct/indirect emissions
- Boundary for CFP is more confined and reduces variability in results
- Life Cycle Assessment is a tool to account for more than the CFP
- CFP output: inventory, dynamic time-series, etc.
- LCA includes human health and environmental management effects (e.g., carcinogens, land use)
- LCA needs weighing factors to sum all components
- LCA output: single-score comparison of scenarios

# ENERGY FOOTPRINT

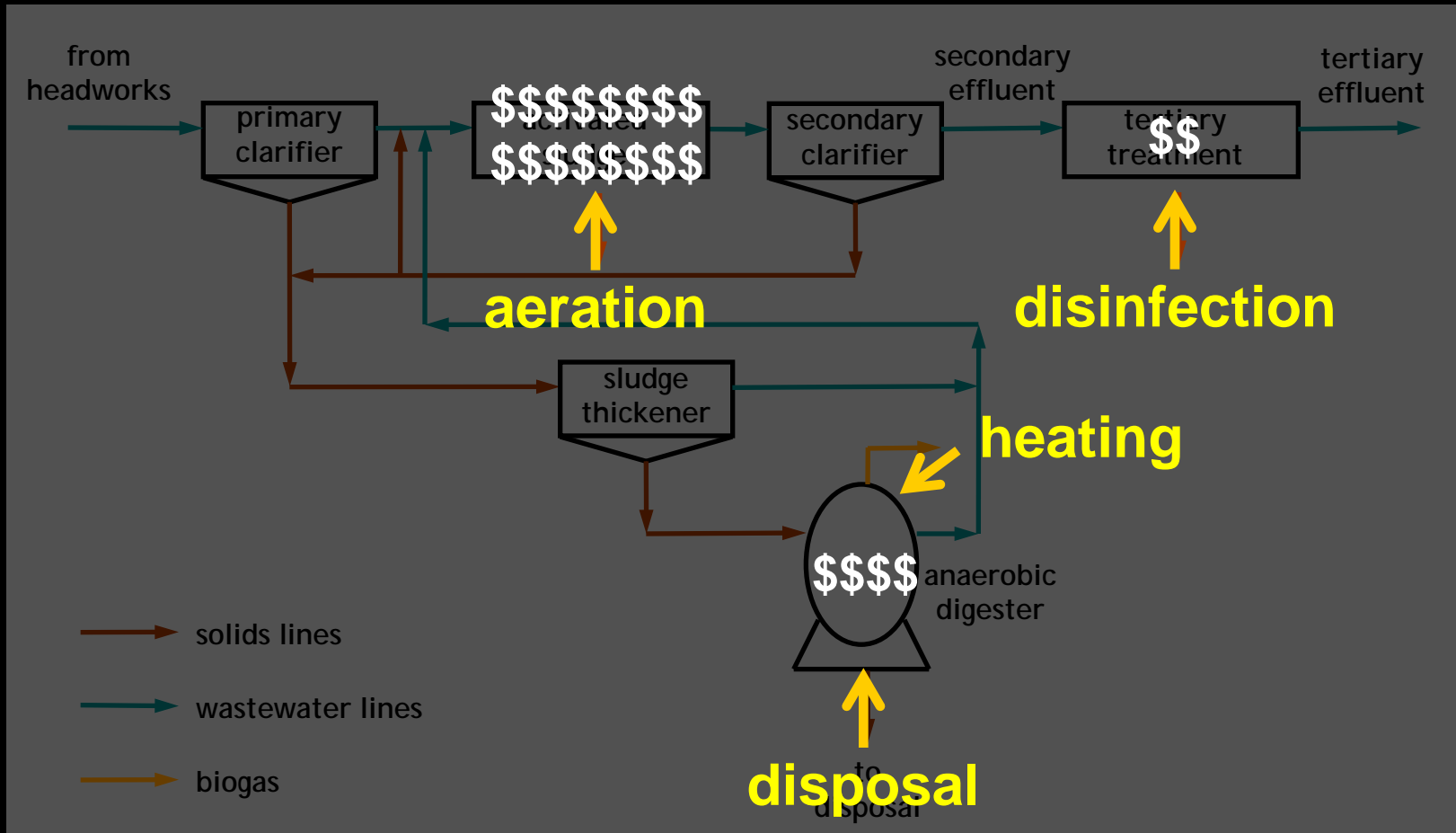

**Aeration cost = 45-75% of plant energy costs**

Rosso and Stenstrom (2005) *Wat. Res.* 39: 3773-3780

# ENERGY FOOTPRINT OF ASPs

ASP layout	Relative cost
CONVENTIONAL	100%
N-only	113%
NDN	88%
<i>Laissez-faire</i> (poorly managed CONV)	>125%

# WHERE DOES THE CARBON GO?

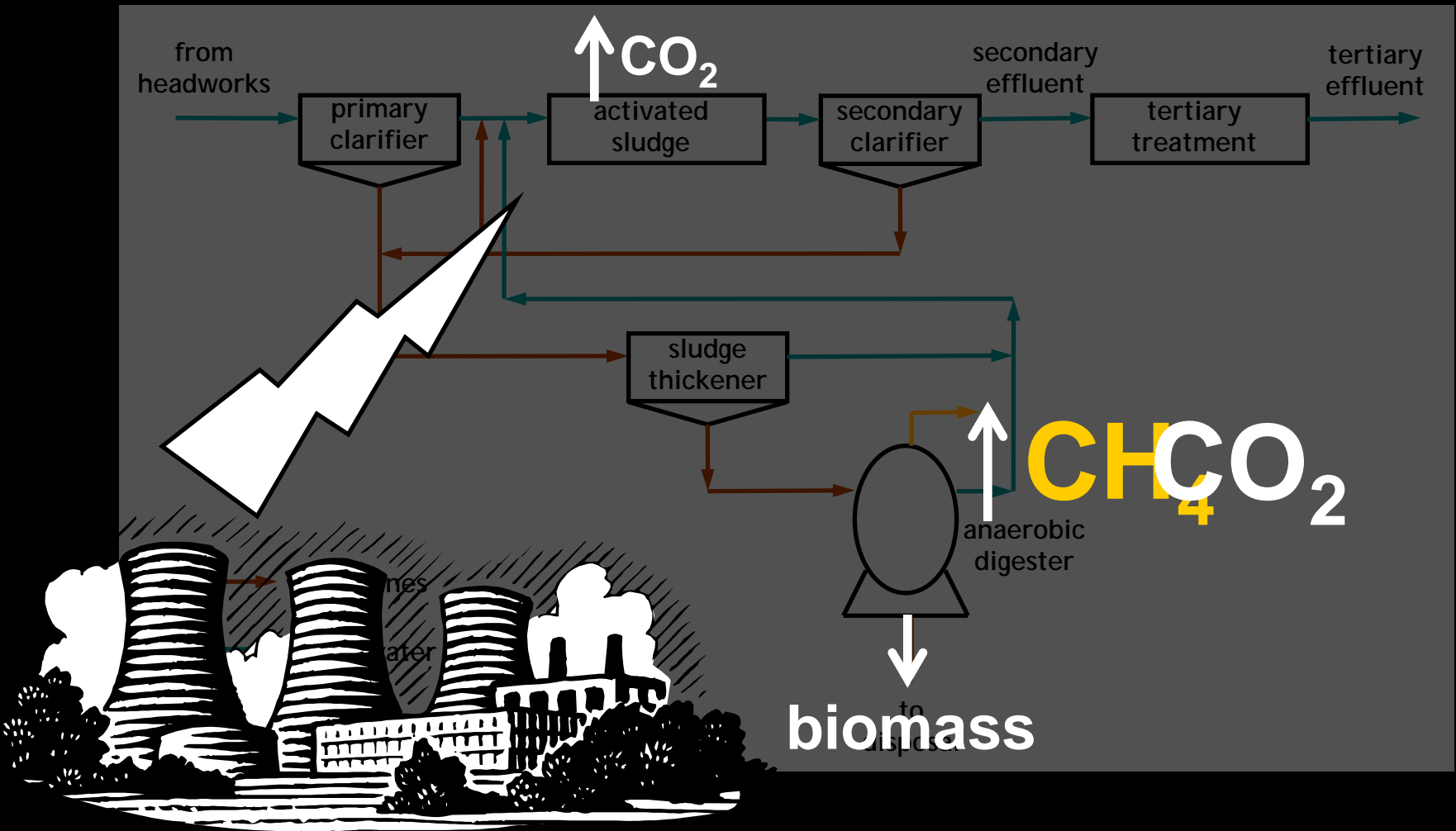

# WHAT ABOUT GHG, such as N<sub>2</sub>O?

- Formed in nature by both N and DN
- 298 times more potent than CO<sub>2</sub>
- Past perceived insignificance
- Measurement challenges
- Formed in the receiving water body without BNR, and also at WWTPs with BNR
- The real problem is the lack of knowledge about it

# N<sub>2</sub>O & NITRIFICATION

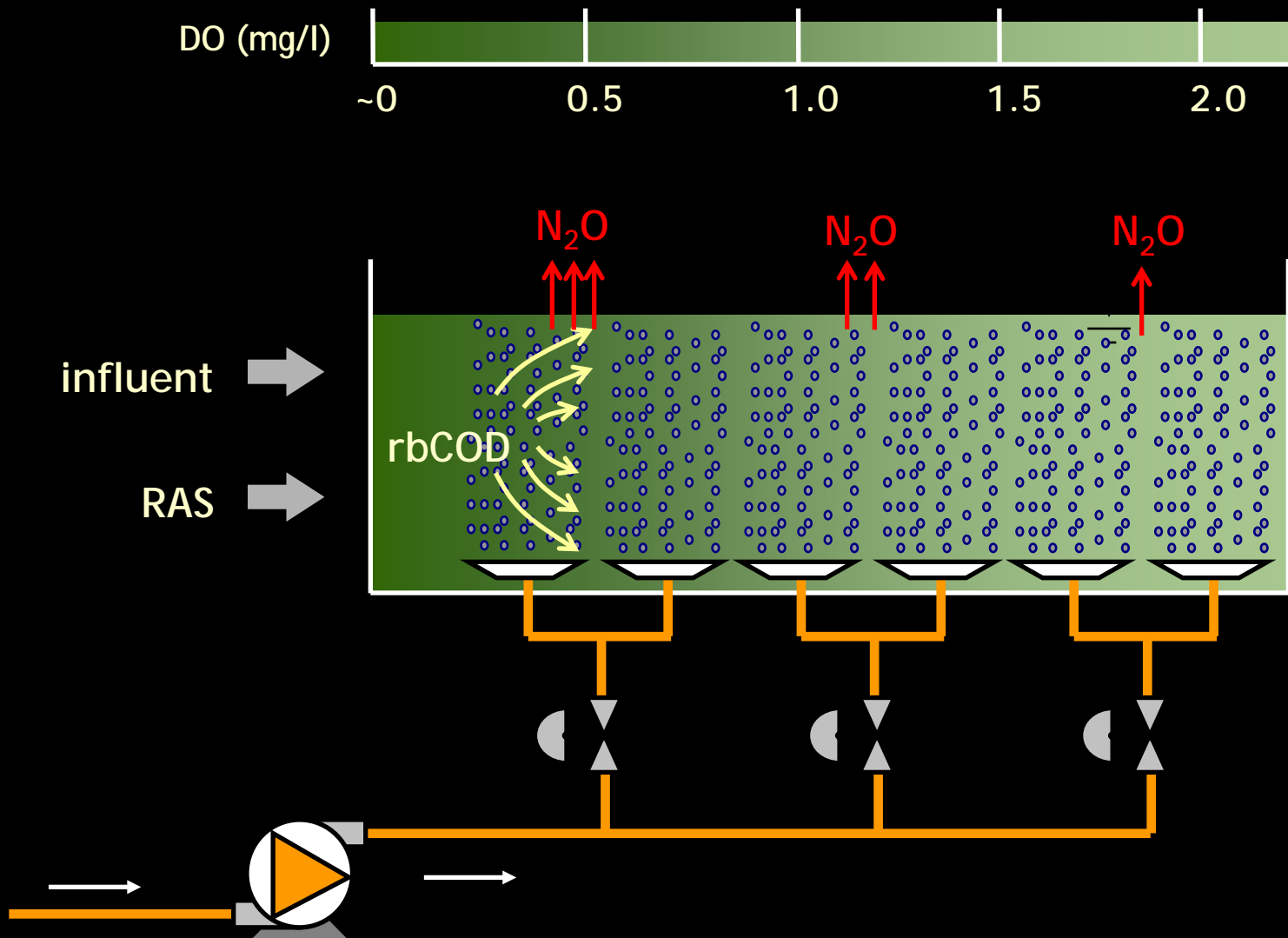

# N<sub>2</sub>O & NITRIFICATION/DENITRIFICATION

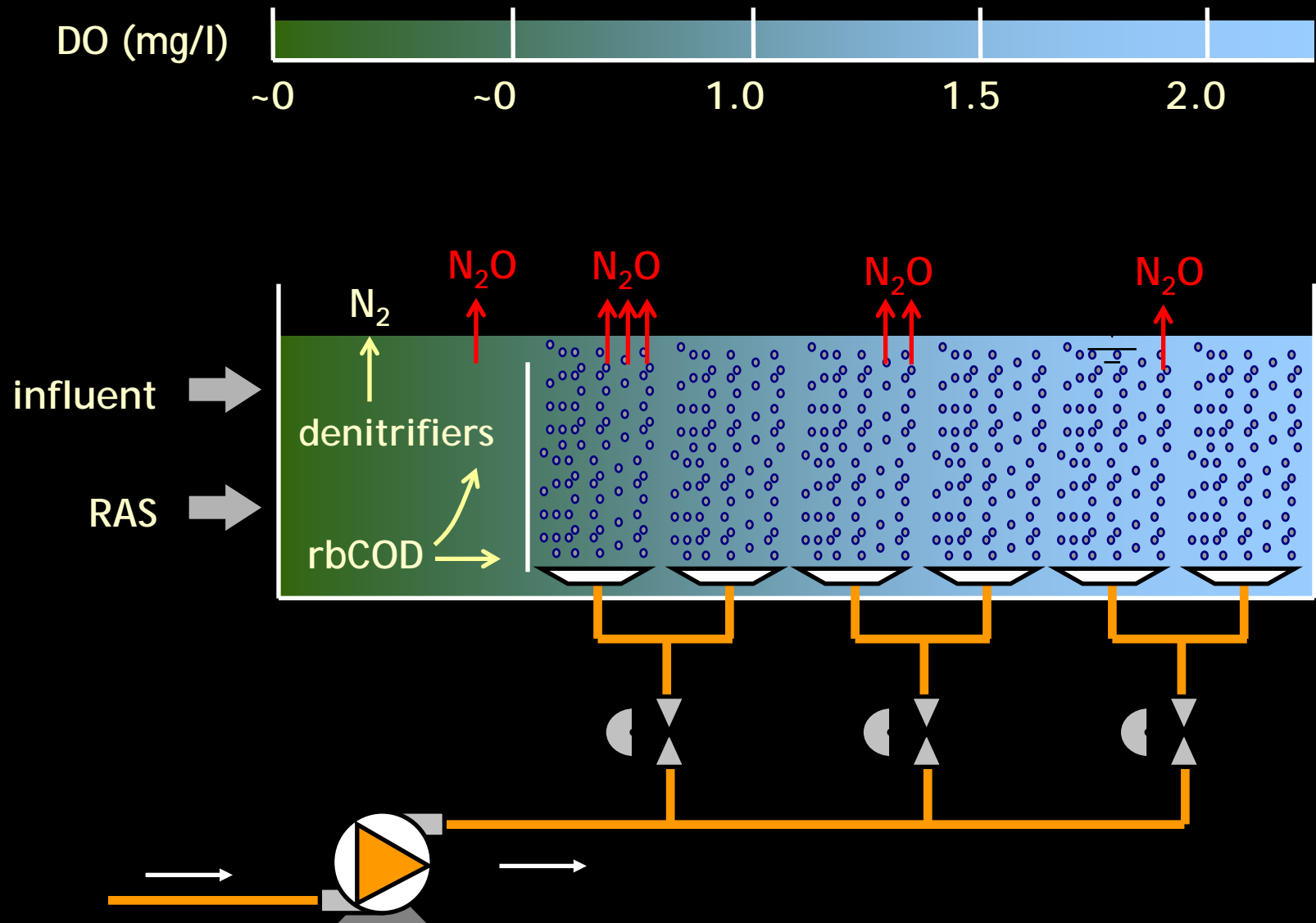

# "TRADITIONAL" OFF-GAS TESTING

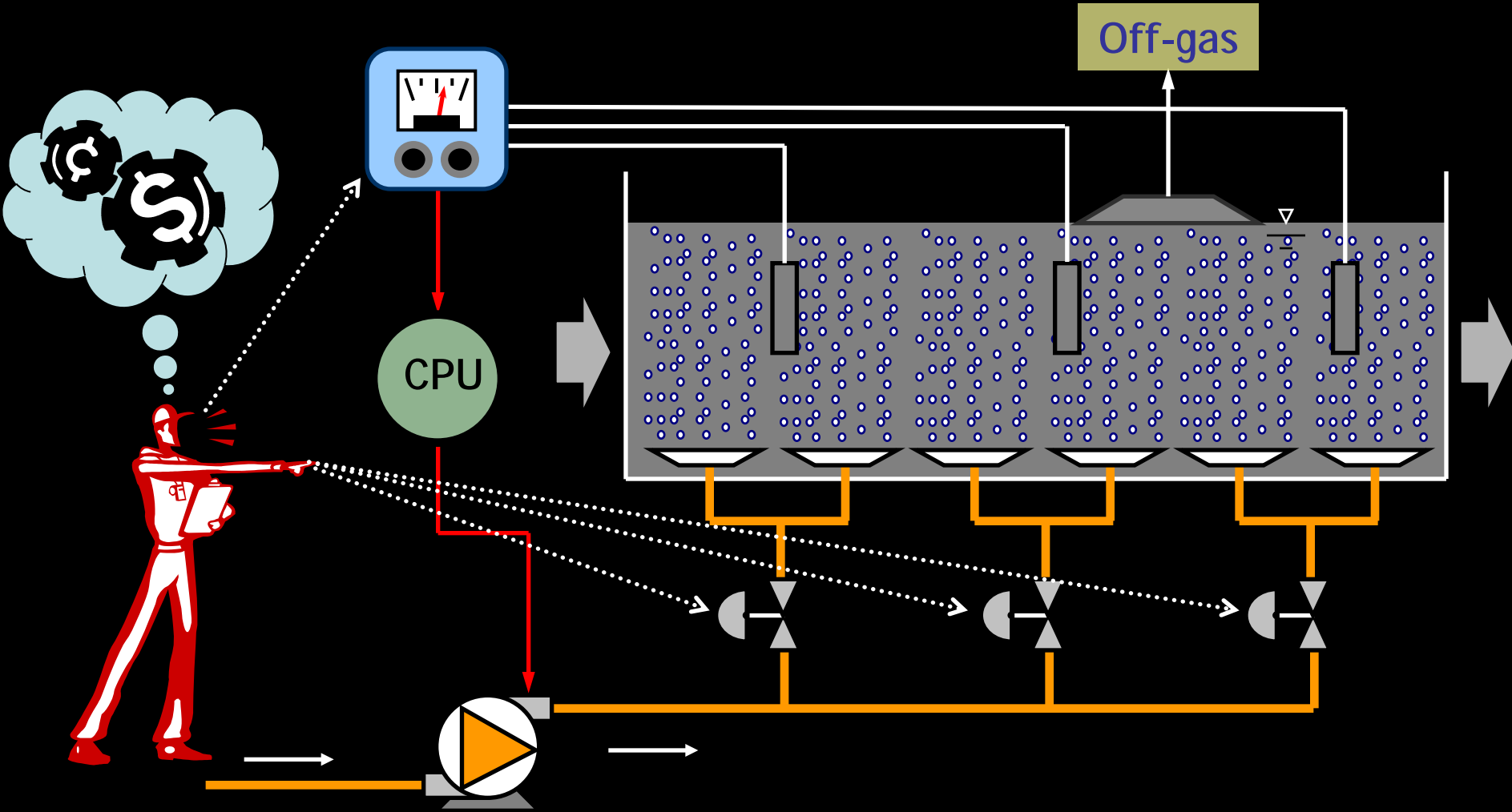

$$\text{OTR} = (k_L a \cdot V) [C_{\text{sat}} - (\text{DO}_{\text{exc}} + \text{DO}_{\text{needed}})] = \text{kg}_{\text{O}_2}/\text{d} = \text{\$/d} = \text{CO}_{2,\text{eq}}/\text{d}$$

# "EVOLVED" OFF-GAS TESTING

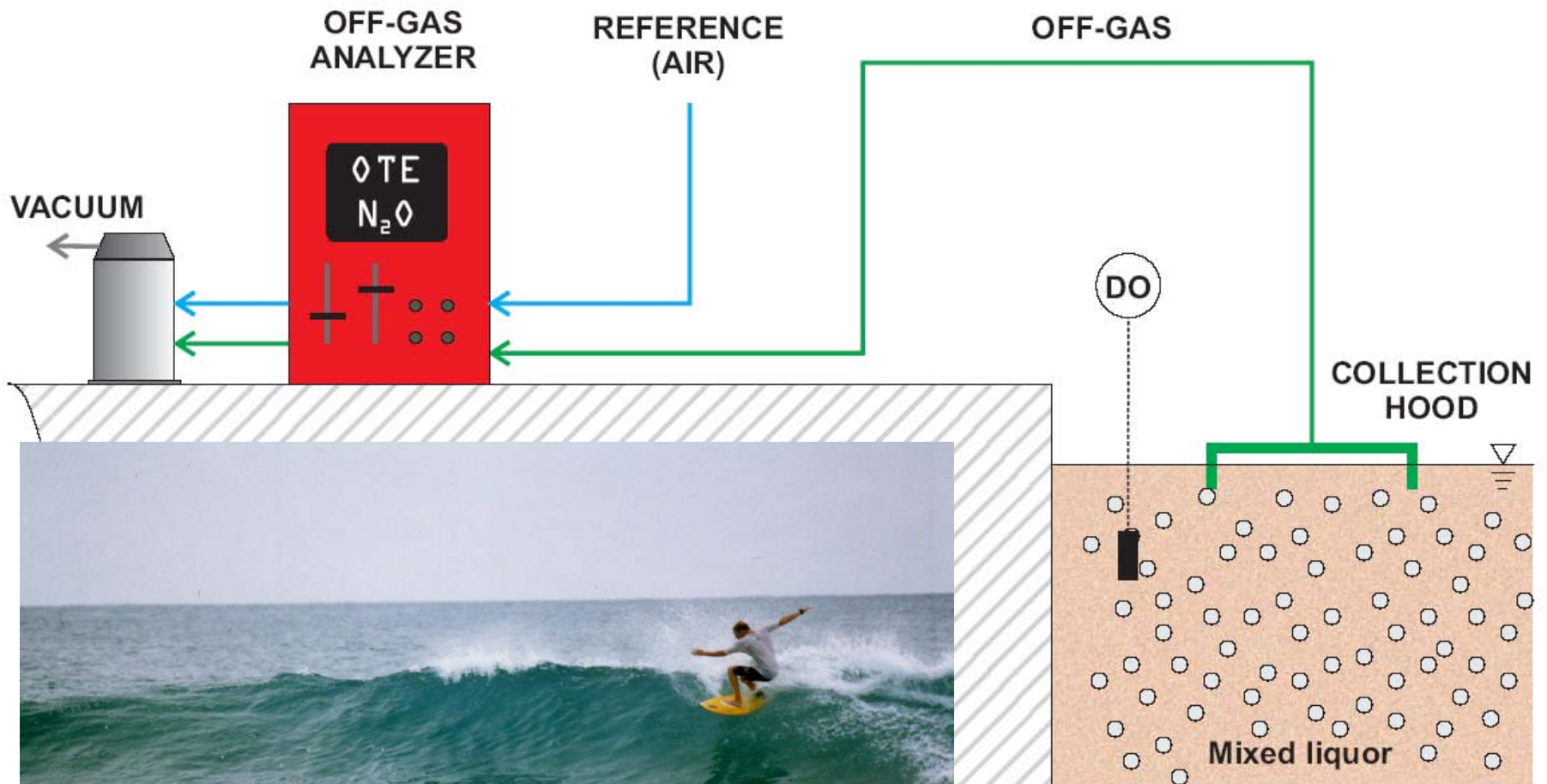

Not me, actually...

# But how much is emitted?

- Dynamic problem: emission factors do not address this issue
- Need for dynamic models to minimize overall emissions

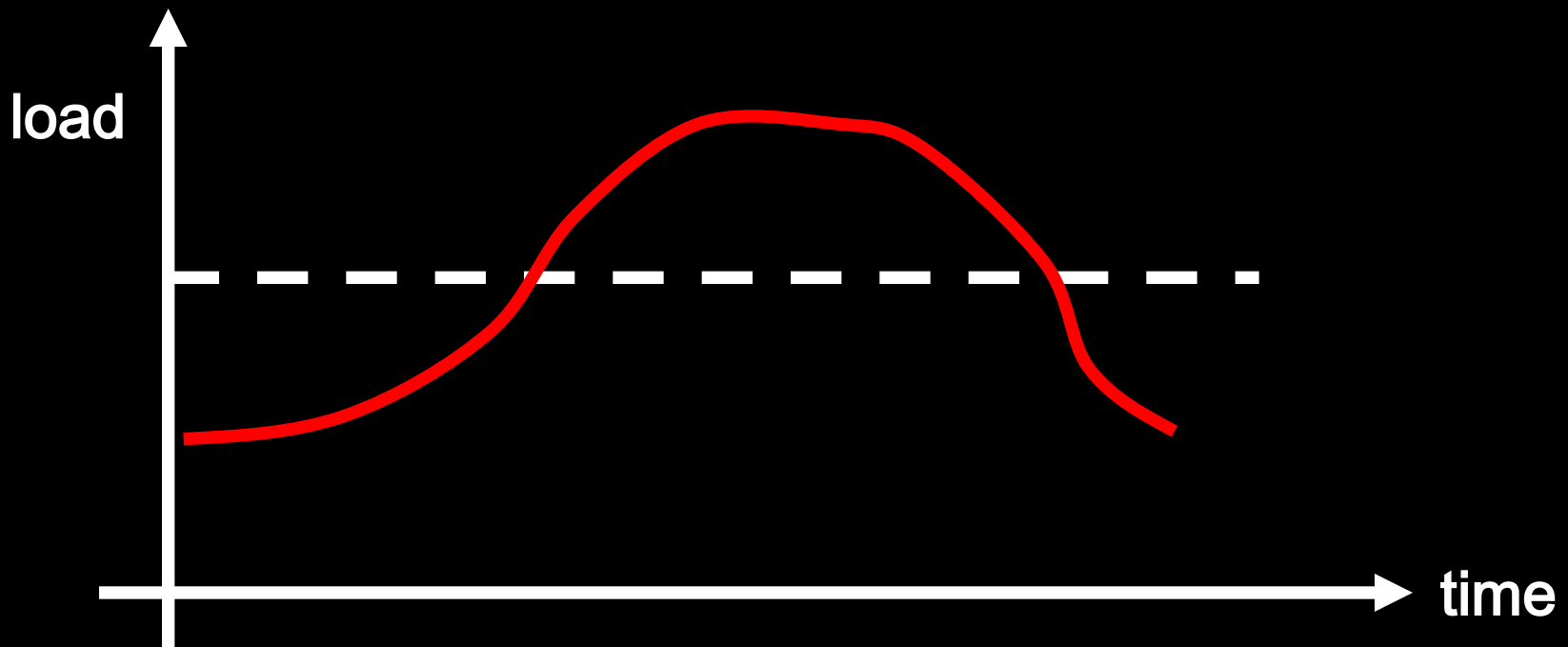



II. CALCULATION (NOT REPORTING!)  
OF CO<sub>2</sub>eq COMPONENTS

# EMISSIONS

BACTERIAL  
RESPIRATION

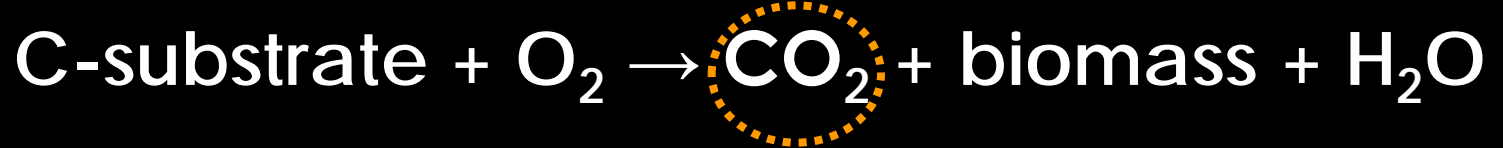

ANAEROBIC  
DIGESTION

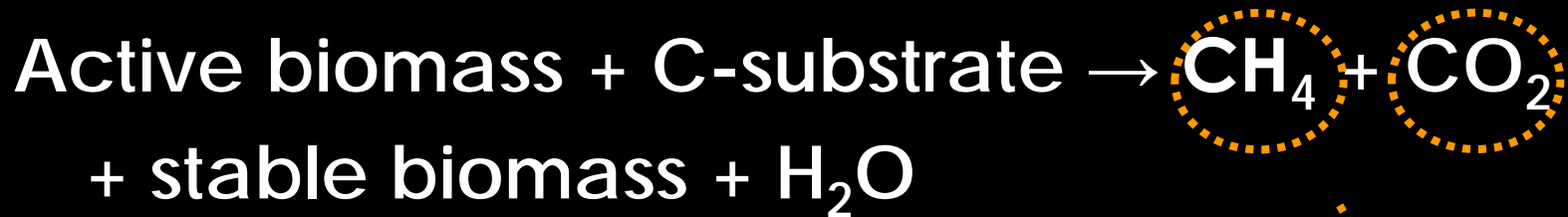

ENERGY  
RECOVERY

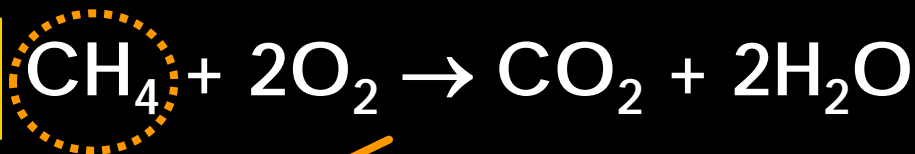

BACTERIAL  
EMISSION



# EMISSIONS (II)

$$CO_{2, emissions} =$$

$$CO_{2, respiration} + CH_{4, emitted} + CH_{4, combusted} + N_2O_{, emitted}$$

Bacterial  
respiration

(Accidental)  
emissions

Combustion  
emissions

Bacterial  
emission

# CREDITS

**Biogas energy recovery:**



= no fossil fuel used to produce the same energy!

**Biomass segregation (when practiced):**



# CREDITS (II)

$$CO_{2, \text{offsets}} =$$

$$CO_{2, \text{eq. biomass}} + CO_{2, \text{energy offset}}$$

Biomass  
sequestration

Fossil fuel  
savings

# How we assume N<sub>2</sub>O emission

$$\text{N}_2\text{O \% emission} = \frac{[\text{N}_2\text{O}]_{\text{emitted}}}{[\text{NH}_4^+]_{\text{removed}}}$$



## III. RESULTS

# Weight of aeration efficiency on process CFP

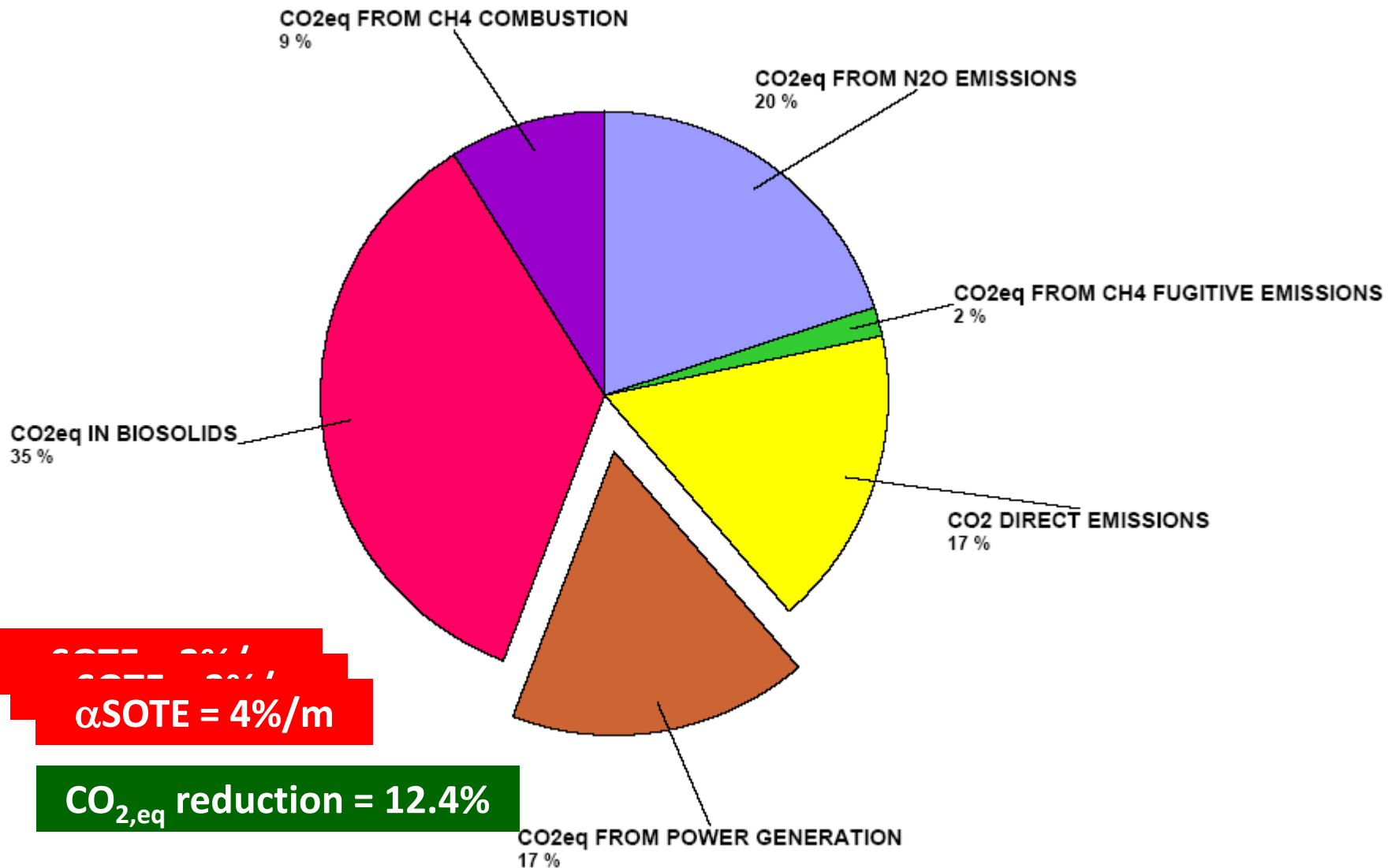

# Weight of N<sub>2</sub>O emission on process CFP

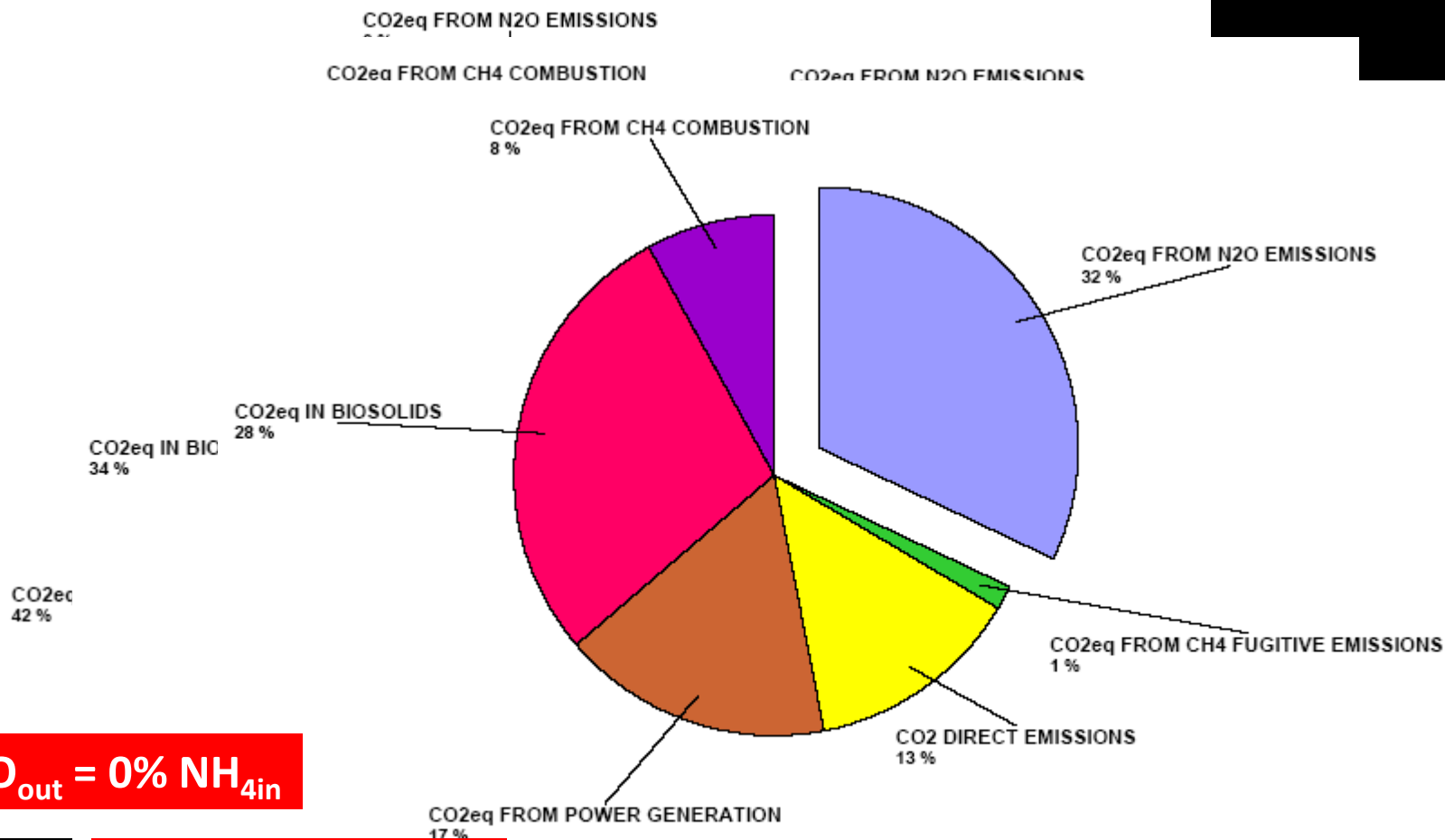

**N<sub>2</sub>O<sub>out</sub> = 0% NH<sub>4in</sub>**

**N<sub>2</sub>O<sub>out</sub> = 0.25% NH<sub>4in</sub>**

**N<sub>2</sub>O<sub>out</sub> = 0.5% NH<sub>4in</sub>**

N<sub>2</sub>O emission = 0.50 % NH<sub>4in</sub>  
 CH<sub>4</sub> fugitive emissions = 2% of biogas  
 αSOTE = 3%/m

# Dynamic CFP output

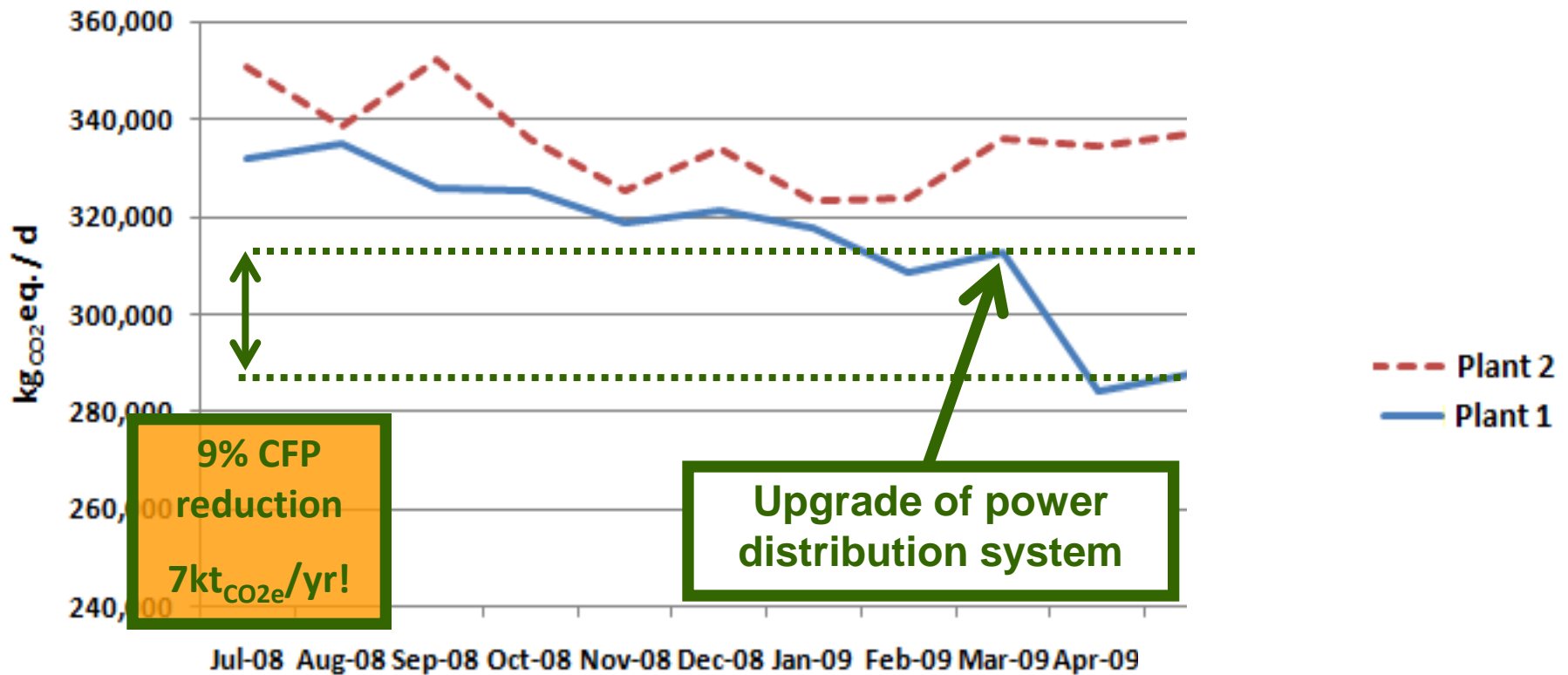

# C-Footprint assumption list

- Mechanical efficiency
- Aeration efficiency
- Digester SRT & Temperature
- VSS destruction
- Fugitive emissions
- Biogas conversion efficiency
- ...

# CAVEAT

*When given a carbon footprint number – always ask what's included and what's not!*

*(A. Shaw)*

# DON'T PANIC!

- WW treatment is important for short-term environmental and public health
- GHG emission reduction is important for long-term environmental health
- GHG are emitted in the receiving environment, if no WW treatment is practiced
- Appreciating the importance of GHG emission does not mean “stop WW treatment”
- More research will give us accurate answers
- **Minimize, not demonize**



# VI. CONCLUSIONS

# Conclusions

- WW treatment offers public health benefits, but GHG are in the picture
- New paradigm: carbon footprint models
- Energy consumption and direct GHG emissions affect CFP
- Process layout affects energy footprint and GHG emissions
- Large margin for improvement: need for research, applications, implementation
- Current and future research: MF/RO/AOP, NP fouling of MF membranes, MBRs

# TAKE HOME MESSAGE

**IN ORDER TO DEVELOP A  
CREDIBLE PROCESS CARBON  
FOOTPRINT MODEL, WE NEED TO  
MEASURE GHGs, ENERGY  
FOOTPRINT, AND MOVE BEYOND  
EMISSION FACTORS**

# QUESTIONS?

DIEGO ROSSO

[bidui@uci.edu](mailto:bidui@uci.edu)

[www.epl.eng.uci.edu](http://www.epl.eng.uci.edu)

- Rosso et al (2005) *Water Environment Research* 77, 266-273
- Rosso and Stenstrom (2005) *Water Research* 39, 3773-3780
- Rosso and Stenstrom (2005) *Water Environment Research* 78, 810-815
- Rosso and Stenstrom (2006) *Water Research* 40, 1397-1404
- Rosso et al (2006) *Water Science & Technology* 54(10), 143-153
- Rosso and Stenstrom (2007) *Environmental Engineer* 43(3), 29-38
- Stenstrom et al (2008) *Water Environment Research* 80(7), 663-671
- Kaliman et al (2008) *Water Research* 42, 467-475
- Rosso et al (2008) *Water Science & Technology* 57(7), 973-978
- Rosso et al (2008) *Water Research* 42, 2640-2648
- *Biological Wastewater Treatment* (2008), IWA Publishing
- Rosso and Stenstrom (2008), *Chemosphere* 70, 1468-1475
- Lippi et al (2009) *Water Science & Technology* 59(1), 125-131
- Rosso and Bolzonella (2009) *Water Environment Research*, submitted
- Rosso and Bolzonella (2009) *Water Science & Technology*, accepted
- Leu et al (2009) *Water Practice & Technology* 3(3)
- Leu et al (2009) *Water Environment Research*, accepted
- Kim et al (2009) *IEEE*, accepted

